

ARTESYN LCM1500 SERIES

1500 Watts Bulk Front End



PRODUCT DESCRIPTION

Advanced Energy's Artesyn LCM1500 series provide for a very wide range of AC-DC embedded power requirement. Featuring high build quality with robust screw terminals, long life, and typical full-load efficiency of greater than 89 percent, these units are ideal for use in industrial and medical applications. They are backed by a comprehensive set of industrial and medical safety approvals and certificates. Variable-speed 'Smart Fans' draw on software controls developed by Advanced Energy to match fan speed to the unit's cooling requirement and load current. Slowing the fan not only saves power but also reduces wear, thus extending its life.

SPECIAL FEATURES

- 1500 Watts output power
- Low cost
- 2.5" x 5.2" x 10.0"
- 12 Watts per cubic inch
- Industrial/medical safety
- -40 °C to 70 °C with derating
- Optional 5 Vdc @ 2 A housekeeping
- High efficiency: 89% typical
- Variable speed "smart fans"
- DSP controlled
- Conformal coat option
- ±10% adjustment range
- Margin programming
- OR-ing FET
- Semi F47 compliance at high line

COMPLIANCE

- EMI Class A
- EN61000 Immunity
- RoHS 3

SAFETY

- ULcUL Recognized
- ITE(UL62368-1)
- ULcUL Recognized Medical(ANSI/AAMI ES60601-1)
- TUV-SuD ITE + Medical (EN62368-1 and EN60601-1)
- CE LVD (EN60950-1 + ROHS)
- BSMI
- UKCA Mark
- CB Report through Demko for IEC60950-1 through TUV-SuD for IEC60601-1

AT A GLANCE

Total Power

1500 Watts

Input Voltage

90 to 264 Vac

of Outputs

Single



MODEL NUMBERS

Standard ¹	Output Voltage	Minimum Load	Maximum Load	Adjustment Range	Maximum Power
LCM1500L	12Vdc	0A	133A	10.8-13.2Vdc	1500W
LCM1500N	15Vdc	0A	100A	13.5-16.5Vdc	1500W
LCM1500Q	24Vdc	0A	67A	21.6-26.4Vdc	1500W
LCM1500R	28Vdc	0A	53A	25.2-30.8Vdc	1500W
LCM1500U	36Vdc	0A	43A	32.4-39.6Vdc	1500W
LCM1500W	48Vdc	0A	33A	43.2-52.8Vdc	1500W

Note 1 - Blank - Standard T- Terminal Block

Options

Blank = No Options

1 = Conformal Coat

2 = Reverse Air

4 = 5V Standby

5 = Opt 1 + 4

8 = Constant current

B = Opt 2 + 8

C = Opt 1 + 2 + 8

D = Opt 4 + 8

E = Opt 1 + 4 + 8

F = Opt 2 + 4 + 8

G = Opt 1 + 2 + 4 + 8

ELECTRICAL SPECIFICATIONS

Absolute Maximum Ratings

Stress in excess of those listed in the “Absolute Maximum Ratings” may cause permanent damage to the power supply. These are stress ratings only and functional operation of the unit is not implied at these or any other conditions above those given in the operational sections of this TRN. Exposure to any absolute maximum rated condition for extended periods may adversely affect the power supply’s reliability.

Table 1. Absolute Maximum Ratings						
Parameter	Model	Symbol	Min	Typ	Max	Unit
Input Voltage AC continuous operation	All models	$V_{IN,AC}$	90	-	264	Vac
Maximum Output Power, continuous	All models	$P_{O,max}$	-	-	1500	W
Isolation Voltage (Qualification) Input to outputs (2X MOPP) Input to safety ground (1X MOPP) Outputs to safety ground (1X MOPP)	All models		-	-	4000 2087 250	Vac Vac Vdc
Isolation Voltage (Production) Input to outputs Input to safety ground Outputs to safety ground	All models All models All models		- - -	- - -	1800 1800 250	Vac Vac Vdc
Ambient Operating Temperature	All models	T_A	-40	-	+70 ¹	°C
Storage Temperature	All models	T_{STG}	-40	-	+85	°C
Humidity (non-condensing) Operating Non-operating	All models All models		20 10	- -	90 95	% %
Altitude Operating Non-operating	All models All models		- -	- -	16,404 30,000	feet feet

Note 1 - With linear 50% derating from 50 °C to 70 °C.

ELECTRICAL SPECIFICATIONS

Input Specifications

Table 2. Input Specifications						
Parameter	Condition	Symbol	Min	Typ	Max	Unit
Operating Input Voltage, AC	All	$V_{IN,AC}$	90	115/230	264	Vac
Input AC Frequency	All	f_{IN}	47	50/60	440	Hz
Maximum Input Current ($I_O = I_{O,max}$, $I_{SB} = I_{SB,max}$)	$V_{IN,AC} = 90Vac$	$I_{IN,max}$	-	-	18	A
No Load Input Current ($V_O = On$, $I_O = 0A$, $I_{SB} = 0A$)	$V_{IN,AC} = 90Vac$ $V_{IN,AC} = 264Vac$	$I_{IN,no-load}$	- -	- -	600 400	mA
No Load Input Power ($V_O = On$, $I_O = 0A$, $I_{SB} = 0A$)	$V_{IN,AC} = 90Vac$	$P_{IN,no-load}$	-	-	32	W
Harmonic Line Currents	All	THD	IEC61000-3-2			
Power Factor	$I_O = I_{O,max}$ $V_{IN,AC} = 90$ to $264Vac$	PF	-	0.99	-	
Startup Surge Current (Inrush) @ 25°C	$V_{IN,AC} = 264Vac$	$I_{IN,surge}$	-	-	25	A_{PK}
Input Fuse	Internal, L and N 250VAC rated		-	-	30	A
Input AC Low Line Start-up Voltage	$I_O = I_{O,max}$	$V_{IN,AC-start}$	85	-	90	Vac
Input AC Undervoltage Lockout Voltage	$I_O = I_{O,max}$	$V_{IN,AC-stop}$	80	-	90	Vac
PFC Switching Frequency	All	$f_{SW,PFC}$	65	-	75	KHz
Efficiency ($T_A = 25°C$, forced air cooling)	$V_{IN,AC} = 230Vac$ $I_O = I_{O,max}$	η	-	89	-	%
Leakage Current to safety ground	UL test method	$I_{IN,leakage}$	-	-	0.4	mA
	IEC test method	$I_{IN,leakage}$	-	-	0.5	mA

ELECTRICAL SPECIFICATIONS

Output Specifications

Table 3. Output Specifications							
Parameter		Condition	Symbol	Min	Typ	Max	Unit
Factory Set Voltage	LCM1500L	$V_{IN,AC} = 230Vac$ Half load	$V_{O,Factory}$	11.94	12.00	12.06	Vdc
	LCM1500N			14.92	15.00	15.07	
	LCM1500Q			23.88	24.00	24.12	
	LCM1500R			27.86	28.00	28.14	
	LCM1500U			35.82	36.00	36.18	
	LCM1500W			47.76	48.00	48.24	
Output Adjust Range	LCM1500L	$I_o = 0A$	V_o	10.8	-	13.2	Vdc
	LCM1500N			13.5	-	16.5	
	LCM1500Q			21.6	-	26.4	
	LCM1500R			25.2	-	30.8	
	LCM1500U			32.4	-	39.6	
	LCM1500W			43.2	-	52.8	
Total Regulation	Inclusive of line, load temperature change, warm-up drift		V_o	-2.0	-	+2.0	% V_o
			V_{SB}	4.8	-	5.48	V
Output Ripple, pk-pk	LCM1500L	See note 2	V_o	-	-	120	mV _{pk-pk}
	LCM1500N			-	-	150	
	LCM1500Q			-	-	240	
	LCM1500R			-	-	280	
	LCM1500U			-	-	360	
	LCM1500W			-	-	480	
	All models		V_{SB}	-	-	50	
Hold Up Time	See note 1		$t_{Hold-Up}$	14	-	-	mSec
DC DC Switching Frequency	All		$f_{SW,DC-DC}$	125	-	145	KHz
Output Current, continuous	LCM1500L	All	$I_{O,max}$	0	-	133	A
	LCM1500N			0	-	100	
	LCM1500Q			0	-	67	
	LCM1500R			0	-	53.6	
	LCM1500U			0	-	43	
	LCM1500W			0	-	33	
	All models			I_{SB}	-	-	

Note 1 - Adjusting the Output to higher tolerance (i.e. 26.4V which is the +10% adjustment range of 24V Nominal) will give a typical Hold-up of 10mSec.

Note 2 - Measure with a 0.1uF ceramic capacitor in parallel with a 10uF tantalum capacitor using a 20MHz bandwidth limited oscilloscope. Measurement circuit needs to be made at PSU terminals or at mating connector.

ELECTRICAL SPECIFICATIONS

Output Specifications

Table 3. Output Specifications							
Parameter	Condition	Symbol	Min	Typ	Max	Unit	
V _O Dynamic Response	50% load change, slew rate = 1A/uS step load valid between 10% to 100% of I _{O,max}	±%V _O t _s	-	-	4	% uSec	
			-	-	300		
Turn On Overshoot	I _O = 0	%V _O	-	-	10	%	
Load Capacitor	LCM1500L	All	C _O	0	-	20000	uF
	LCM1500N			0	-	16000	
	LCM1500Q			0	-	10000	
	LCM1500R			0	-	8200	
	LCM1500U			0	-	6700	
	LCM1500W			0	-	5000	
	All models	C _{SB}	0	-	270		
Number of Parallel Units	All		-	-	10	Units	
V _O Current Share Accuracy	100% of I _{O,max}				10	%I _{O,max}	
Minimum Load for Current Sharing			1	-	-	%I _{O,max}	

ELECTRICAL SPECIFICATIONS

System Timing Specifications

Table 4. Specifications					
Label	Parameter	Min	Typ	Max	Unit
T1	Delay from AC being applied to output voltages being within regulation.	-	-	3000	mSec
T2	V _O rise time, 10% to 90% of the nominal voltage.	-	-	100	mSec
T3	Delay from main output within regulation to G_DCOK_C signal assertion (going Low).	-	-	500	mSec
T4	Delay from loss of AC input to 0 to G_ACOK_C going to high.	-	-	50	mSec
T5	Delay from AC loss to main output being within regulation. Main output set at nominal voltage setting	14	-	-	mSec
T6	Delay from G_DCOK_C signal de-assertion (going High) to main output dropping to less than the lower trimming range (-20% of the nominal output).	1	-	-	mSec
T7	Delay from INH_EN active to output voltages within regulation limits.	-	-	500	mSec
T8	Delay from Inhibit assertion (Pulled low) to G_DCOK_C signal going High.	-	-	2	mSec

ELECTRICAL SPECIFICATIONS

System Timing Diagram

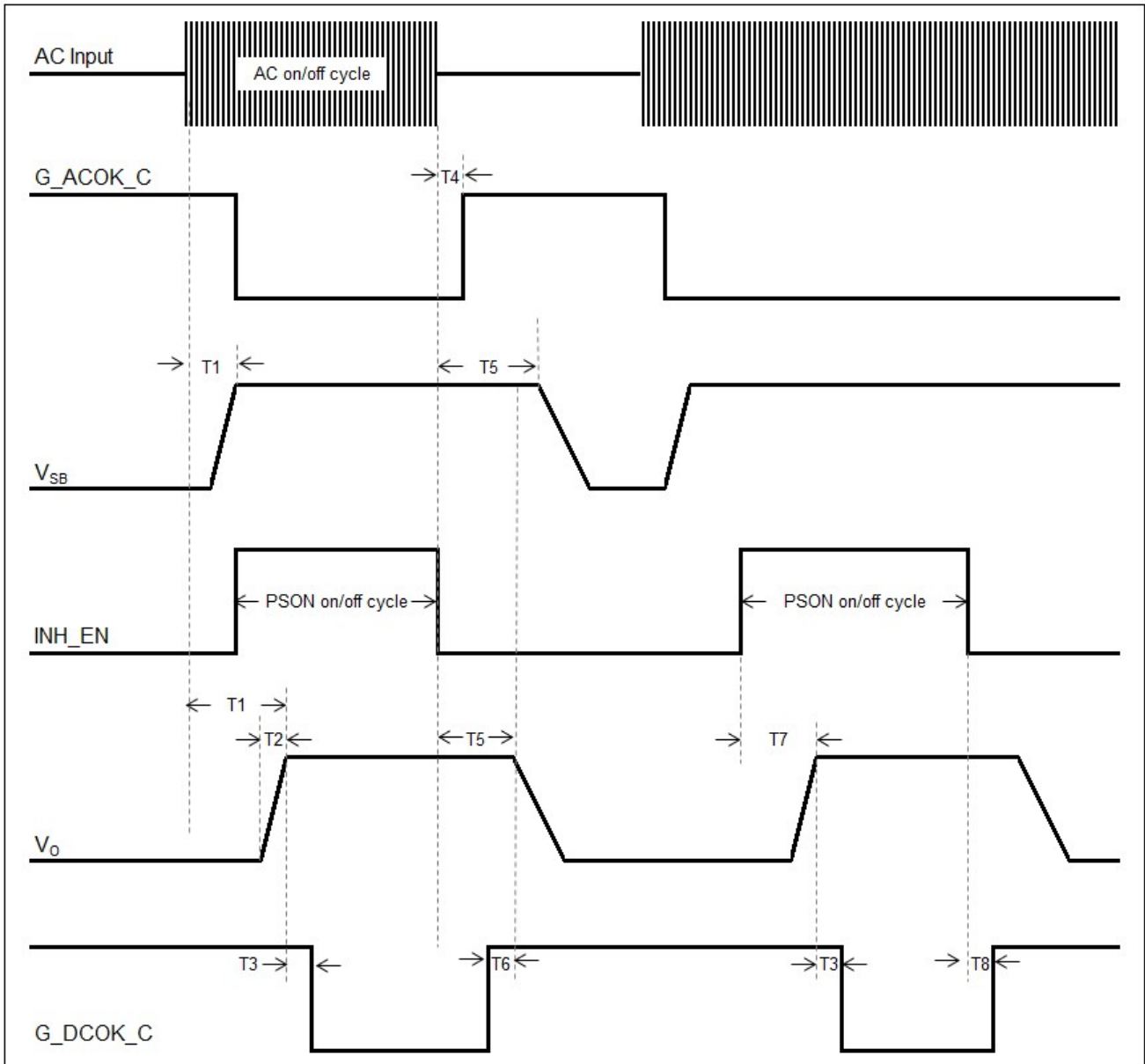

ELECTRICAL SPECIFICATIONS

LCM1500L Performance Curves

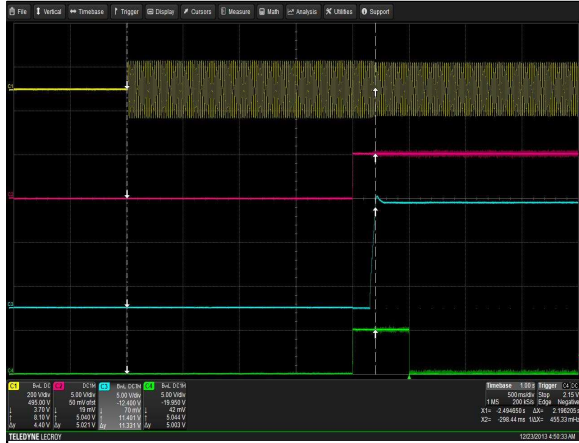

Figure 1: LCM1500L-T-4 Turn-on delay via AC mains
 Vin = 90Vac Load: lo = 125A (12V), Isb = 2A (5V)
 Ch 1: Vin Ch 2: Vsb Ch 3: Vo Ch 4: G_DCOK_C

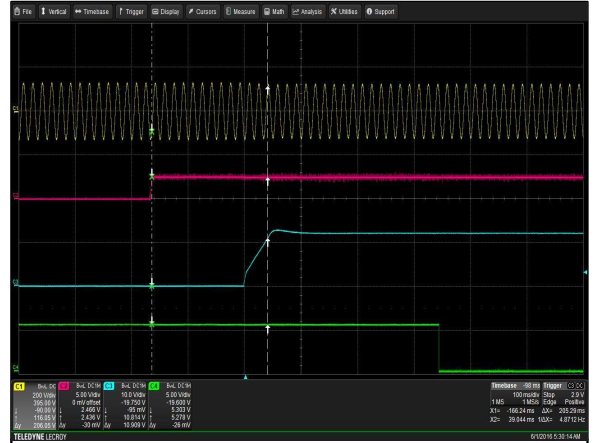

Figure 2: LCM1500L-T-4 Turn-on delay via INH_EN
 Vin = 90Vac Load: lo = 125A (12V), Isb = 2A (5V)
 Ch 1: Vin Ch 2: INH_EN Ch 3: Vo Ch 4: G_DCOK_C



Figure 3: LCM1500L-T-4 Hold-up Time
 Vin = 90Vac / 47Hz / 0° Load: lo = 125A (12V), Isb = 2A (5V)
 Ch 1: Vin Ch 2: Vsb Ch 3: Vo Ch 4: G_DCOK_C

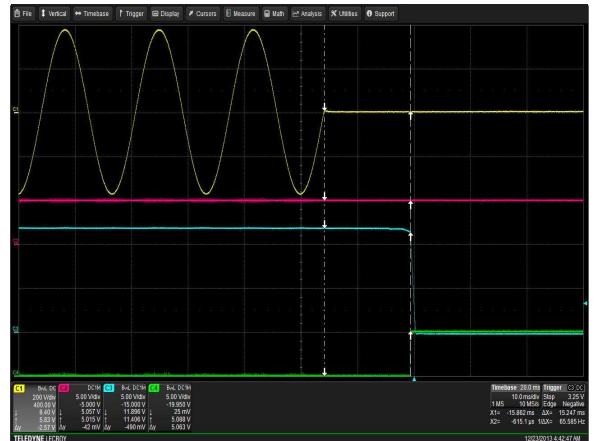

Figure 4: LCM1500L-T-4 Hold-up Time
 Vin = 264Vac / 60Hz / 0° Load: lo = 125A (12V), Isb = 2A (5V)
 Ch 1: Vin Ch 2: Vsb Ch 3: Vo Ch 4: G_DCOK_C

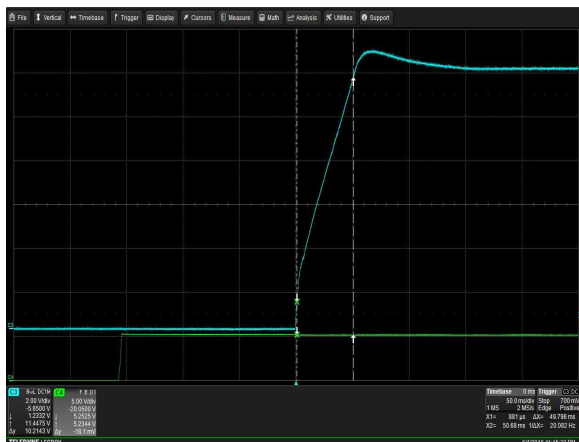

Figure 5: LCM1500L-T-4 Output Voltage Startup
 Vin = 90Vac Load: lo = 125A (12V), Isb = 2A (5V)
 Ch 3: Vo Ch 4: G_DCOK_C

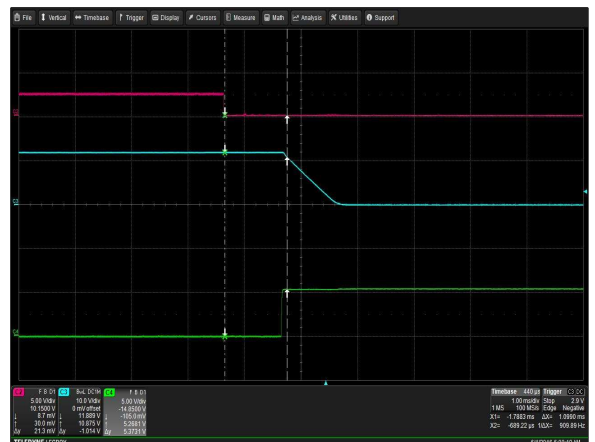

Figure 6: LCM1500L-T-4 Turn Off Characteristic via INH_EN
 Load: lo = 125A (12V), Isb = 2A (5V)
 Ch 2: INH_EN Ch 3: Vo Ch 4: G_DCOK_C

ELECTRICAL SPECIFICATIONS

LCM1500L Performance Curves

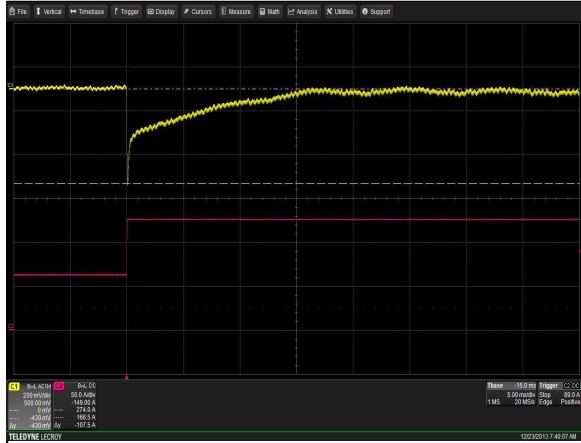

Figure 7: LCM1500L-T-4 Transient Response - Vo Deviation
50% to 100% load change 1A/uS slew rate Vin = 230Vac
Ch 1: Vo Ch 2: Io

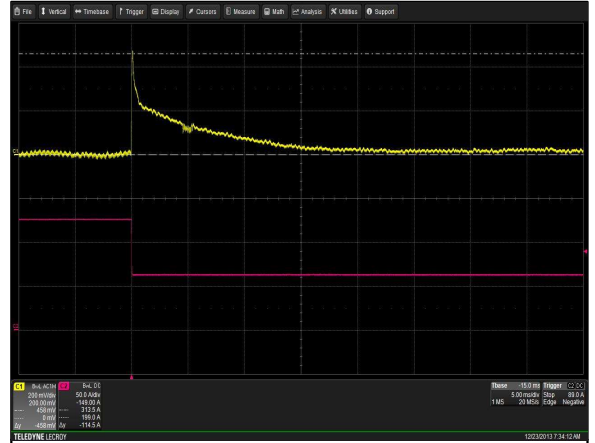

Figure 8: LCM1500L-T-4 Transient Response - Vo Deviation
100% to 50% load change 1A/uS slew rate Vin = 230Vac
Ch 1: Vo Ch 2: Io

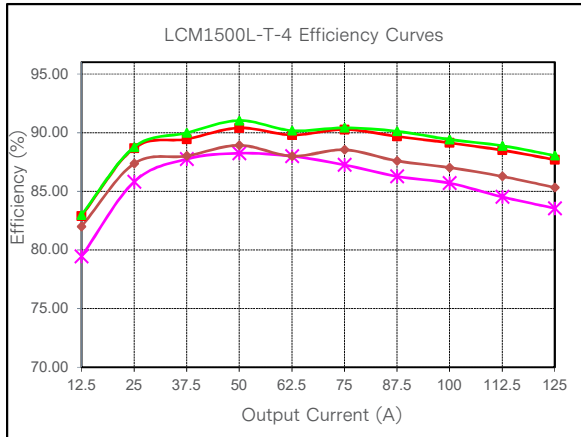

Figure 9: LCM1500L-T-4 Efficiency Curve @ 25°C
— 90Vac — 115Vac — 230Vac — 264Vac
Loading: $I_{o_main} = 10\%I_{o_max}$ increment to 125A, $I_{SB} = 0A$ (5V)



Figure 10: LCM1500L-T-4 Ripple and Noise Measurement
Vin = 115Vac Load: $I_o = 125A$ (12V), $I_{sb} = 2A$ (5V)
Ch 1: Vo

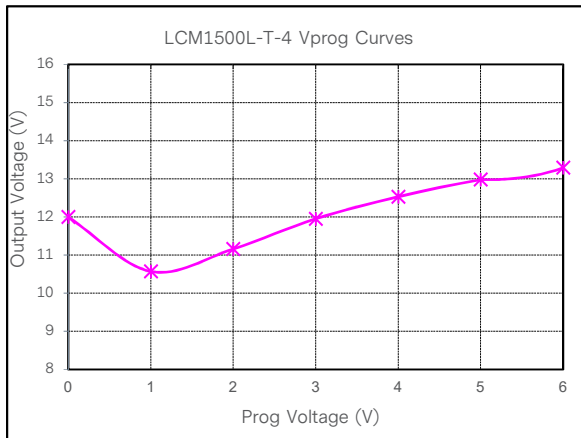

Figure 11: LCM1500L-T-4 Output Voltage Adjustment by Vprog @ 25°C
— 115Vac
Loading: $I_o = 0A$ (12V), $I_{sb} = 0A$ (5V)

ELECTRICAL SPECIFICATIONS

LCM1500N Performance Curves

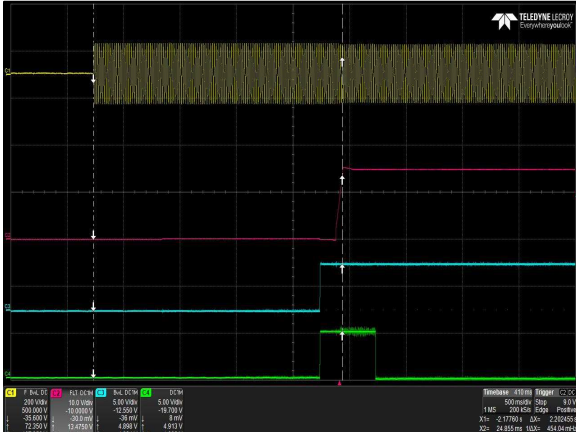

Figure 12: LCM1500N-T-4 Turn-on delay via AC mains
 Vin = 90Vac Load: lo = 100A (15V), Isb = 2A (5V)
 Ch 1: Vin Ch 2: Vsb Ch 3: Vo Ch 4: G_DCOK_C

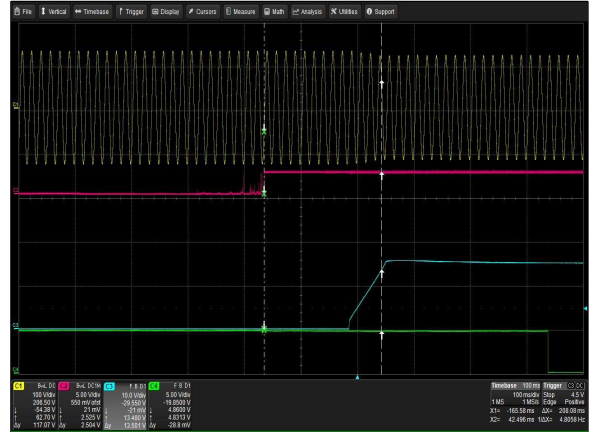

Figure 13: LCM1500N-T-4 Turn-on delay via INH_EN
 Vin = 90Vac Load: lo = 100A (15V), Isb = 2A (5V)
 Ch 1: Vin Ch 2: INH_EN Ch 3: Vo Ch 4: G_DCOK_C



Figure 14: LCM1500N-T-4 Hold-up Time
 Vin = 90Vac / 47Hz / 0° Load: lo = 100A (15V), Isb = 2A (5V)
 Ch 1: Vin Ch 2: Vsb Ch 3: Vo Ch 4: G_DCOK_C



Figure 15: LCM1500N-T-4 Hold-up Time
 Vin = 264Vac / 60Hz / 0° Load: lo = 100A (15V), Isb = 2A (5V)
 Ch 1: Vin Ch 2: Vsb Ch 3: Vo Ch 4: G_DCOK_C

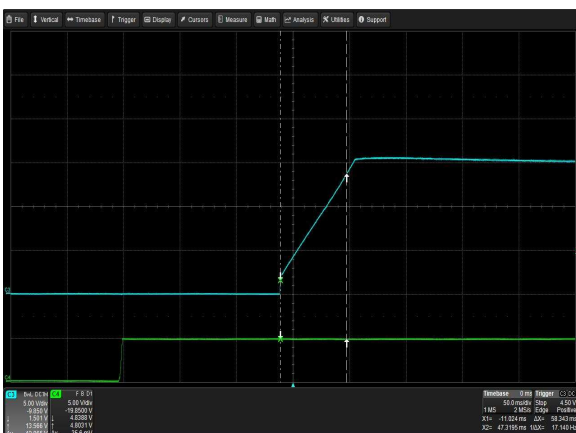

Figure 16: LCM1500N-T-4 Output Voltage Startup
 Vin = 90Vac Load: lo = 100A (15V), Isb = 2A (5V)
 Ch 1: Vo Ch 2: G_DCOK_C

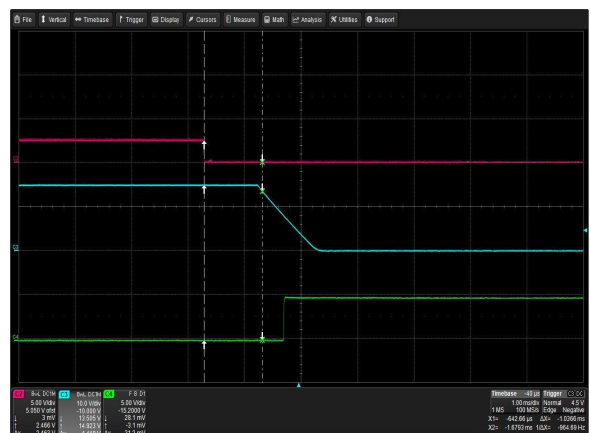

Figure 17: LCM1500N-T-4 Turn Off Characteristic via INH_EN
 Load: lo = 100A (15V), Isb = 2A (5V)
 Ch 1: INH_EN Ch 2: Vo Ch 3: G_DCOK_C

ELECTRICAL SPECIFICATIONS

LCM1500N Performance Curves

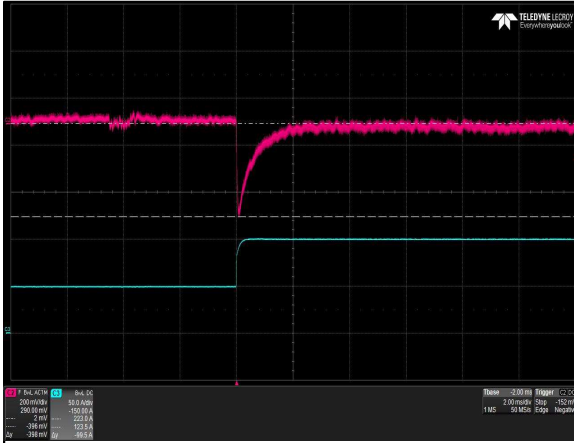

Figure 18: LCM1500N-T-4 Transient Response - Vo Deviation
50% to 100% load change 1A/uS slew rate Vin = 230Vac
Ch 1: Vo Ch 2: Io

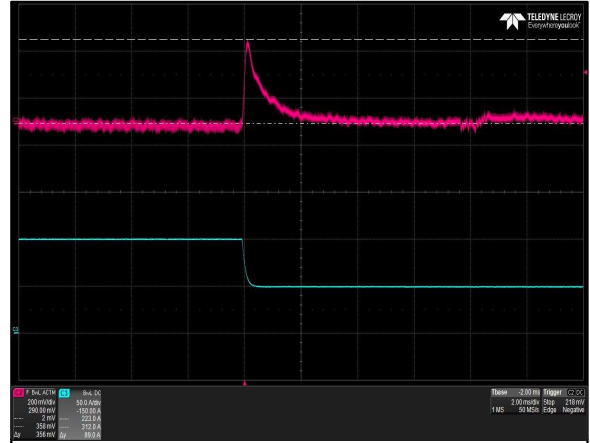

Figure 19: LCM1500N-T-4 Transient Response - Vo Deviation
100% to 50% load change 1A/uS slew rate Vin = 230Vac
Ch 1: Vo Ch 2: Io

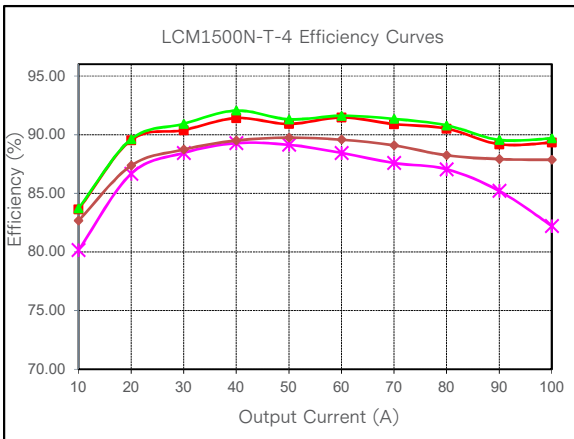

Figure 20: LCM1500N-T-4 Efficiency Curve @ 25°C
— 90Vac — 115Vac — 230Vac — 264Vac
Loading: $I_{o_main} = 10\%I_{o_max}$ increment to 100A, $I_{SB} = 0A$ (5V)

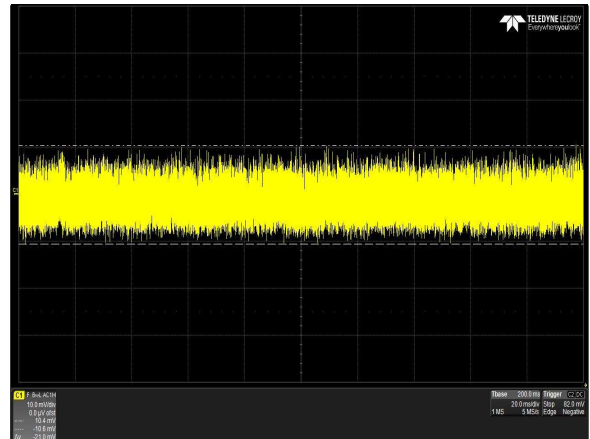

Figure 21: LCM1500N-T-4 Ripple and Noise Measurement
Vin = 115Vac Load: Io = 100A (15V), Isb = 2A (5V)
Ch 1: Vo

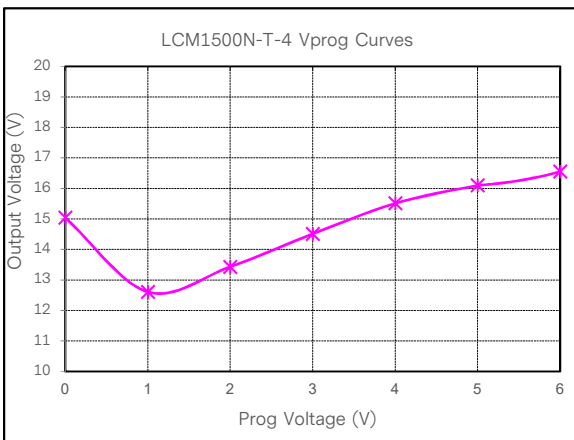

Figure 22: LCM1500N-T-4 Output Voltage Adjustment by Vprog @ 25°C
— 115Vac
Loading: $I_o = 0A$ (15V), $I_{SB} = 0A$ (5V)

ELECTRICAL SPECIFICATIONS

LCM1500Q Performance Curves

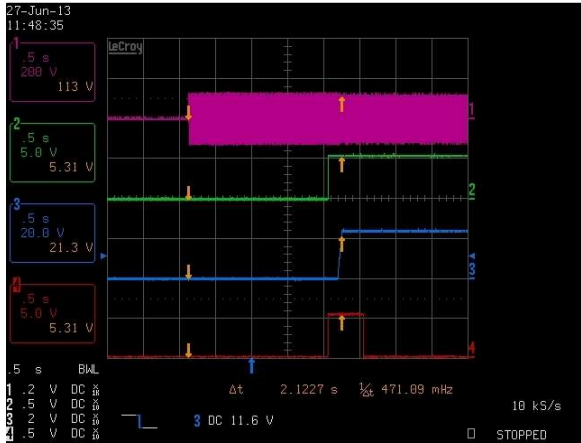

Figure 23: LCM1500Q-T-4 Turn-on delay via AC mains
 Vin = 90Vac Load: Io = 63A (24V), Isb = 2A (5V)
 Ch 1: Vin Ch 2: Vsb Ch 3: Vo Ch 4: G_DCOK_C

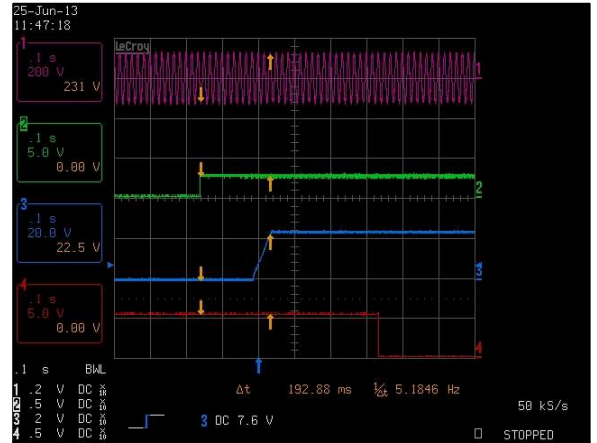

Figure 24: LCM1500Q-T-4 Turn-on delay via INH_EN
 Vin = 90Vac Load: Io = 63A (24V), Isb = 2A (5V)
 Ch 1: Vin Ch 2: INH_EN Ch 3: Vo Ch 4: G_DCOK_C

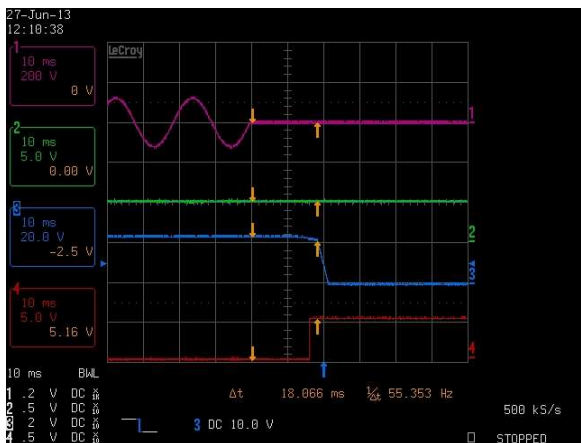

Figure 25: LCM1500Q-T-4 Hold-up Time
 Vin = 90Vac / 47Hz / 0° Load: Io = 63A (24V), Isb = 2A (5V)
 Ch 1: Vin Ch 2: Vsb Ch 3: Vo Ch 4: G_DCOK_C

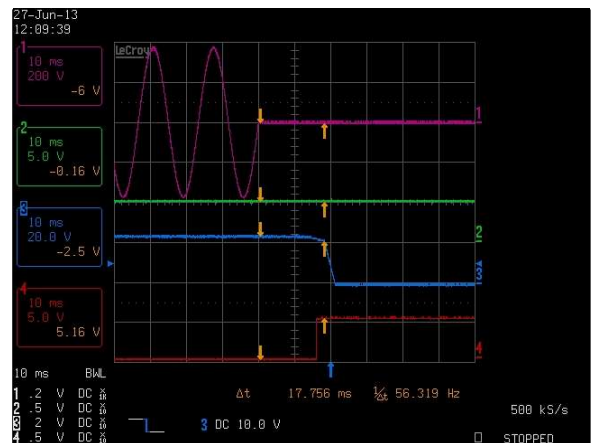

Figure 26: LCM1500Q-T-4 Hold-up Time
 Vin = 264Vac / 60Hz / 0° Load: Io = 63A (24V), Isb = 2A (5V)
 Ch 1: Vin Ch 2: Vsb Ch 3: Vo Ch 4: G_DCOK_C

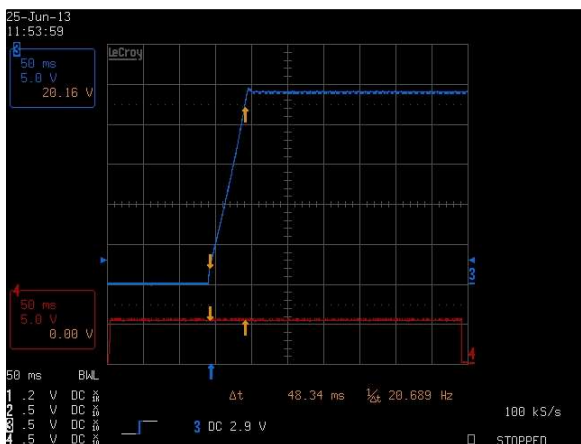

Figure 27: LCM1500Q-T-4 Output Voltage Startup
 Vin = 90Vac Load: Io = 63A (24V), Isb = 2A (5V)
 Ch 3: Vo Ch 4: G_DCOK_C

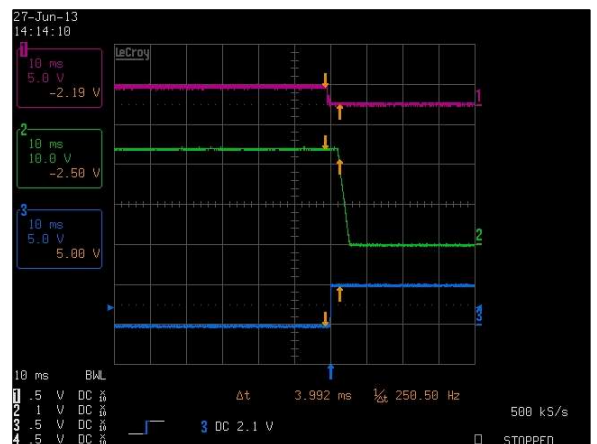

Figure 28: LCM1500Q-T-4 Turn Off Characteristic via INH_EN
 Load: Io = 63A (24V), Isb = 2A (5V)
 Ch 1: INH_EN Ch 2: Vo Ch 3: G_DCOK_C

ELECTRICAL SPECIFICATIONS

LCM1500Q Performance Curves

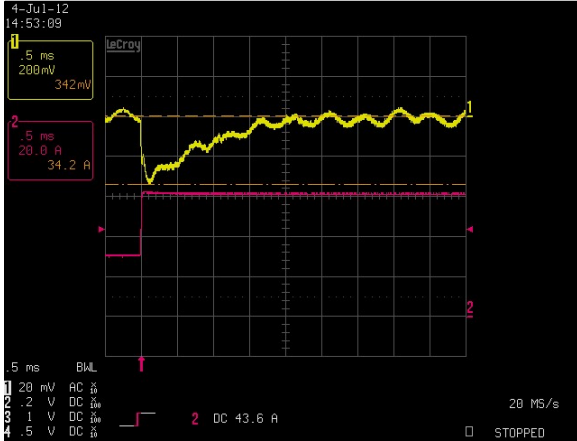

Figure 29: LCM1500Q-T-4 Transient Response - Vo Deviation
50% to 100% load change 1A/uS slew rate Vin = 230Vac
Ch 1: Vo Ch 2: Io

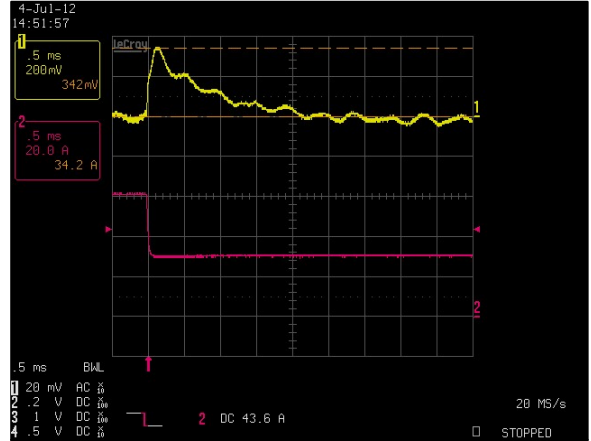

Figure 30: LCM1500Q-T-4 Transient Response - Vo Deviation
100% to 50% load change 1A/uS slew rate Vin = 230Vac
Ch 1: Vo Ch 2: Io

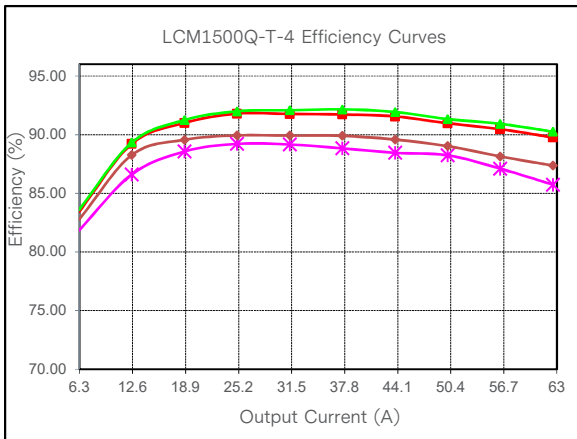

Figure 31: LCM1500Q-T-4 Efficiency Curve @ 25°C
90Vac 115Vac 230Vac 264Vac
Loading: $I_{o_main} = 10\% I_{o_max}$ increment to 63A, $I_{SB} = 0A$ (5V)

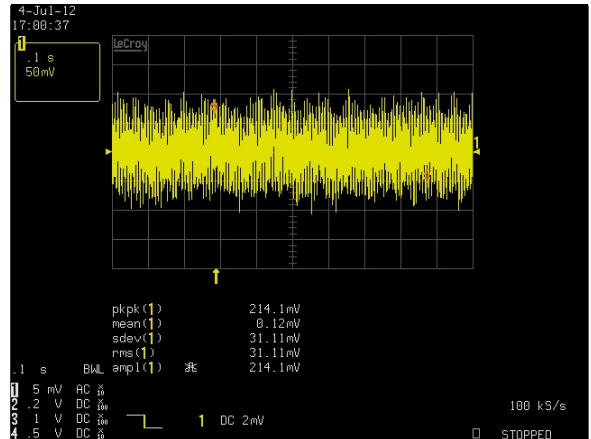

Figure 32: LCM1500Q-T-4 Ripple and Noise Measurement
Vin = 115Vac Load: Io = 63A (24V), Isb = 2A (5V)
Ch 1: Vo

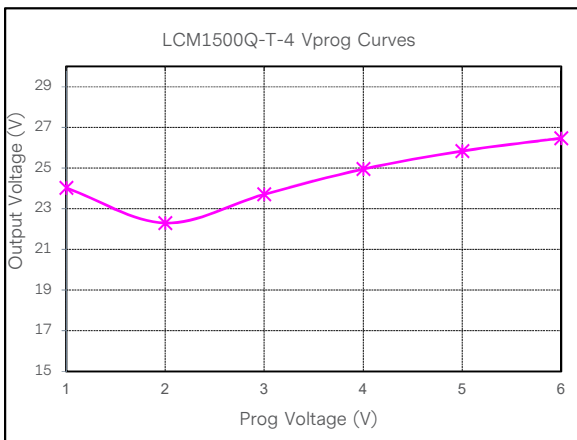

Figure 33: LCM1500Q-T-4 Output Voltage Adjustment by Vprog @ 25°C
115Vac
Loading: $I_o = 0A$ (24V), $I_{SB} = 0A$ (5V)

ELECTRICAL SPECIFICATIONS

LCM1500R Performance Curves

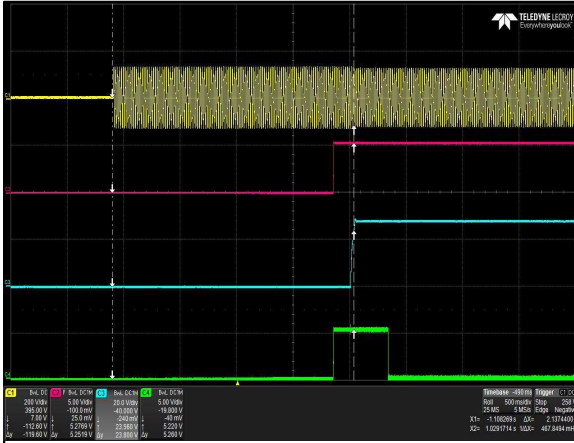

Figure 34: LCM1500R-T-4 Turn-on delay via AC mains
 Vin = 90Vac Load: Io = 53.6A (28V), Isb = 2A (5V)
 Ch 1: Vin Ch 2: Vsb Ch 3: Vo Ch 4: G_DCOK_C

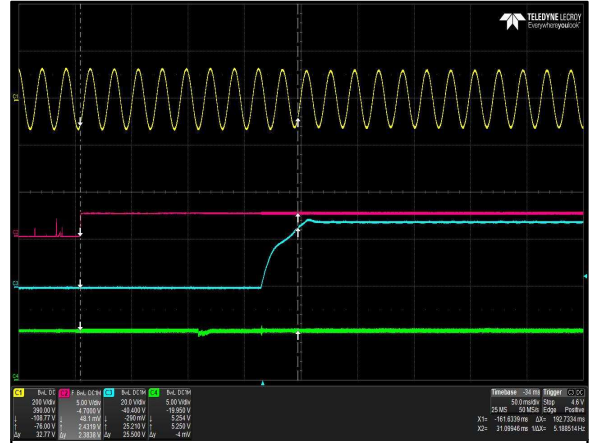

Figure 35: LCM1500R-T-4 Turn-on delay via INH_EN
 Vin = 90Vac Load: Io = 53.6A (28V), Isb = 2A (5V)
 Ch 1: Vin Ch 2: INH_EN Ch 3: Vo Ch 4: G_DCOK_C

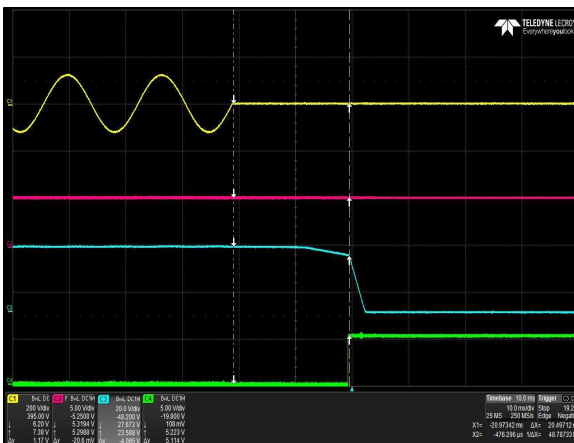

Figure 36: LCM1500R-T-4 Hold-up Time
 Vin = 90Vac / 47Hz / 0° Load: Io = 53.6A (28V), Isb = 2A (5V)
 Ch 1: Vin Ch 2: Vsb Ch 3: Vo Ch 4: G_DCOK_C

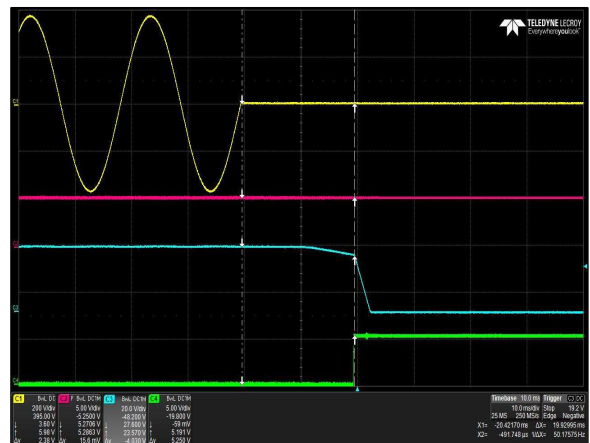

Figure 37: LCM1500R-T-4 Hold-up Time
 Vin = 264Vac / 60Hz / 0° Load: Io = 53.6A (28V), Isb = 2A (5V)
 Ch 1: Vin Ch 2: Vsb Ch 3: Vo Ch 4: G_DCOK_C

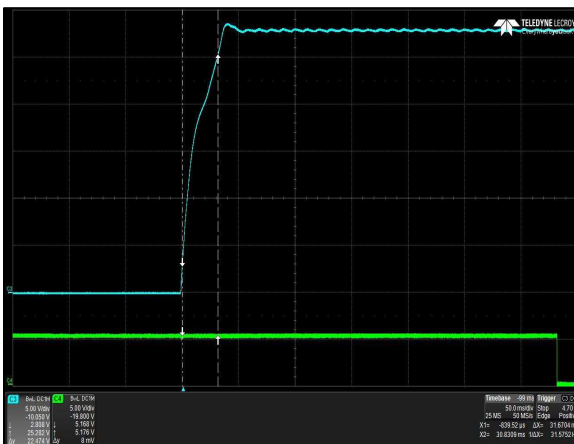

Figure 38: LCM1500R-T-4 Output Voltage Startup
 Vin = 90Vac Load: Io = 53.6A (28V), Isb = 2A (5V)
 Ch 3: Vo Ch 4: G_DCOK_C

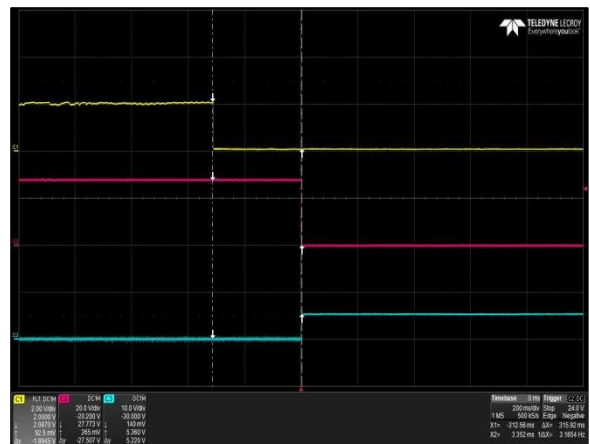

Figure 39: LCM1500R-T-4 Turn Off Characteristic via INH_EN
 Load: Io = 53.6A (28V), Isb = 2A (5V)
 Ch 1: INH_EN Ch 2: Vo Ch 3: G_DCOK_C

ELECTRICAL SPECIFICATIONS

LCM1500R Performance Curves

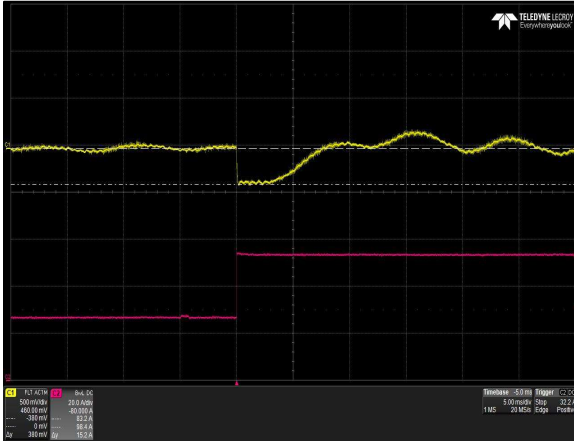

Figure 40: LCM1500R-T-4 Transient Response - Vo Deviation
50% to 100% load change 1A/uS slew rate Vin = 230Vac
Ch 1: Vo Ch 2: Io

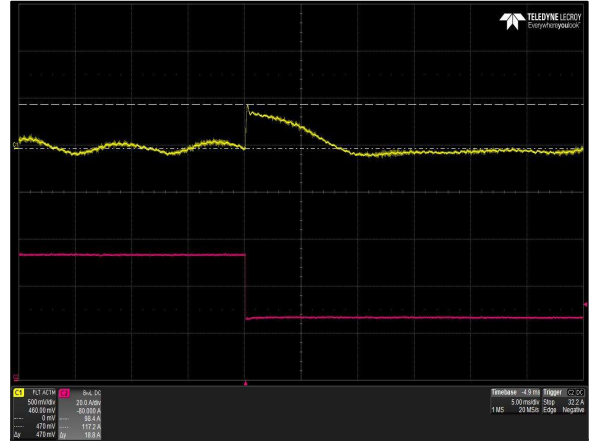

Figure 41: LCM1500R-T-4 Transient Response - Vo Deviation
100% to 50% load change 1A/uS slew rate Vin = 230Vac
Ch 1: Vo Ch 2: Io

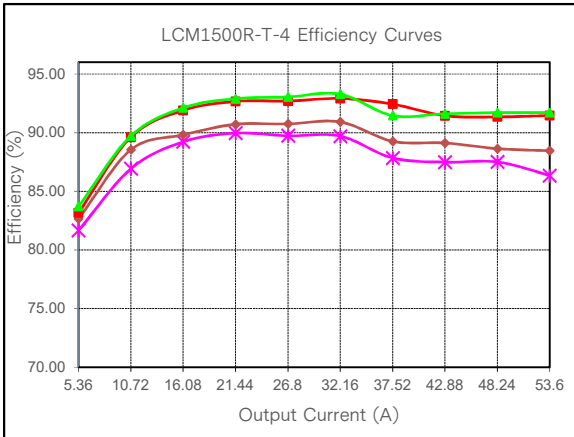

Figure 42: LCM1500R-T-4 Efficiency Curve @ 25°C
Loading: Io_main = 10%Io_max increment to 53.6A, I_{SB} = 0A (5V)



Figure 43: LCM1500R-T-4 Ripple and Noise Measurement
Vin = 115Vac Load: Io = 53.6A (28V), I_{SB} = 2A (5V)
Ch 2: Vo

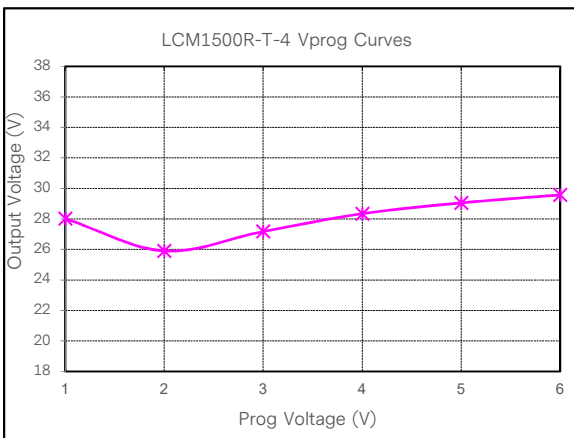
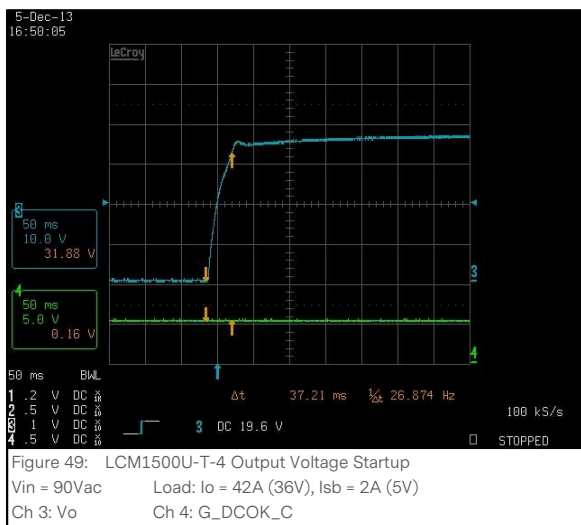
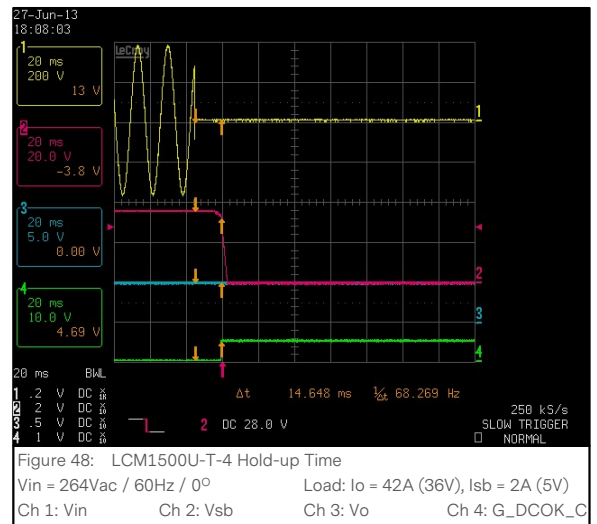
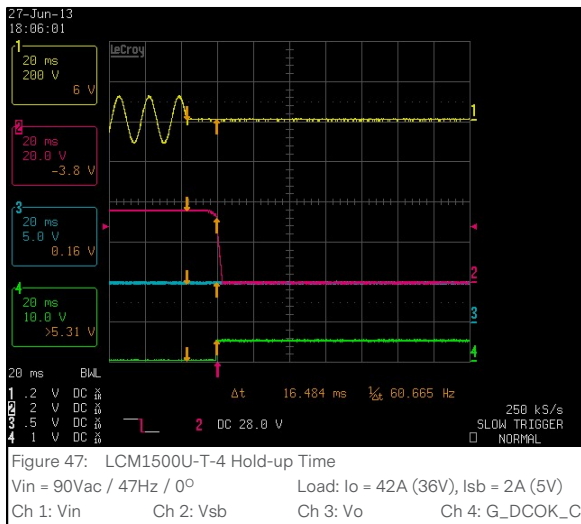
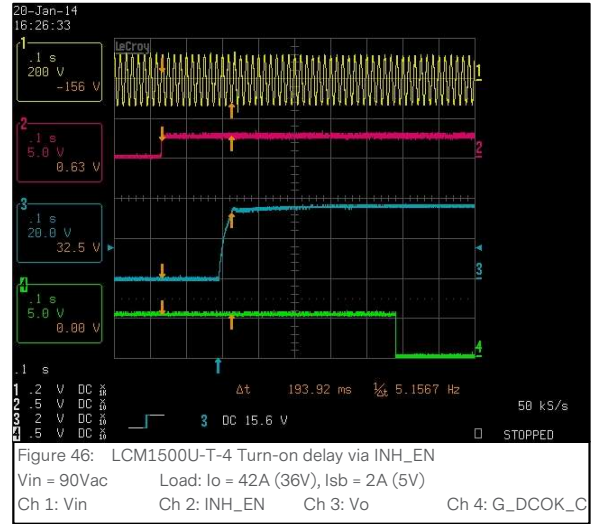
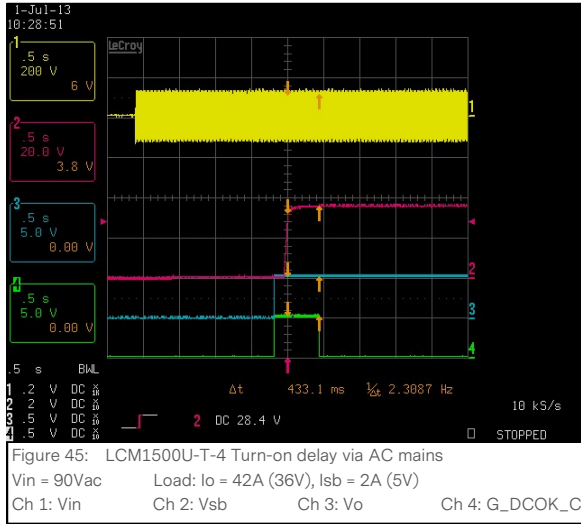

Figure 44: LCM1500R-T-4 Output Voltage Adjustment by Vprog @ 25°C
Loading: Io = 0A (28V), I_{SB} = 0A (5V)

ELECTRICAL SPECIFICATIONS

LCM1500U Performance Curves



ELECTRICAL SPECIFICATIONS

LCM1500U Performance Curves

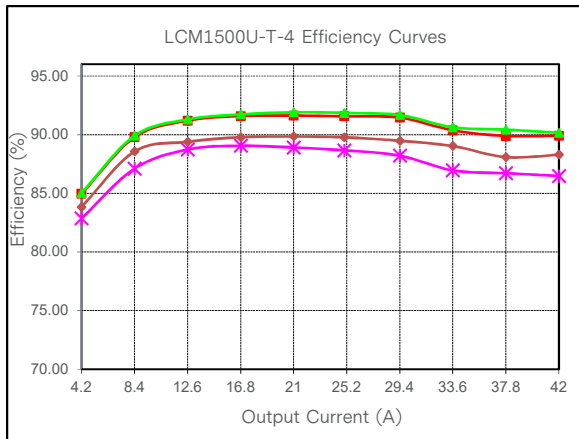
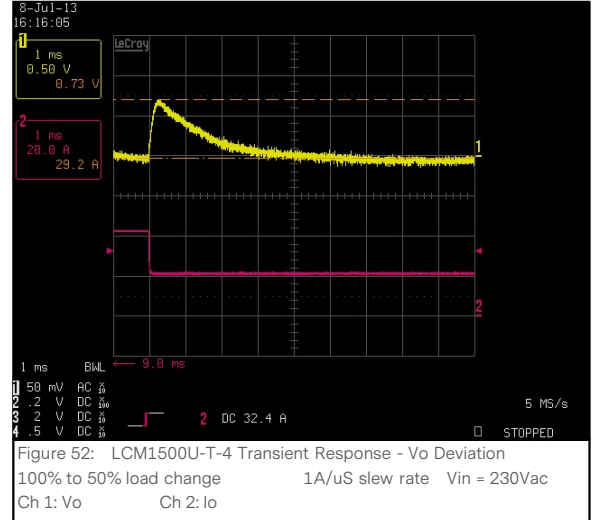
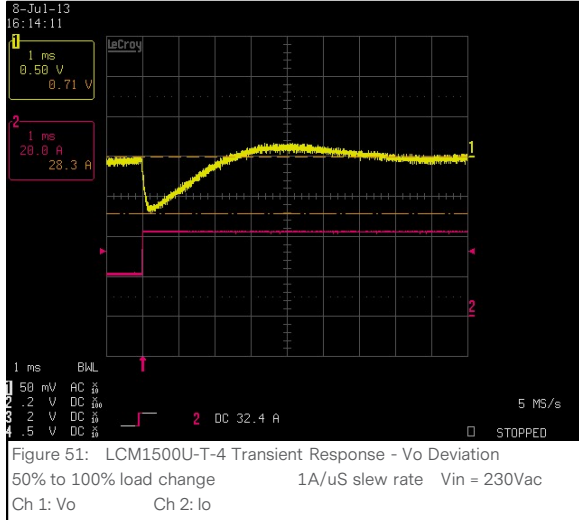

Figure 53: LCM1500U-T-4 Efficiency Curve @ 25°C
 Loading: $I_{o_main} = 10\%I_{o_max}$ increment to 42A, $I_{SB} = 0A$ (5V)

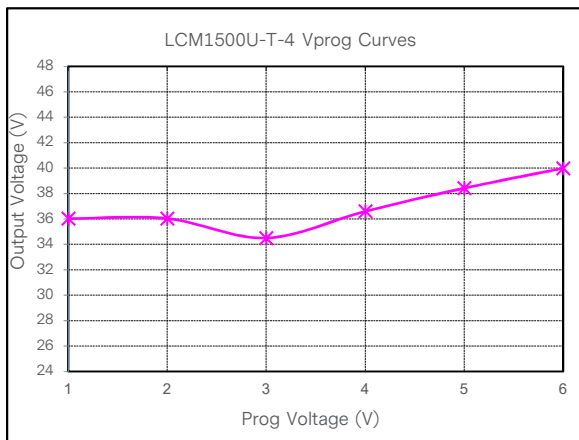
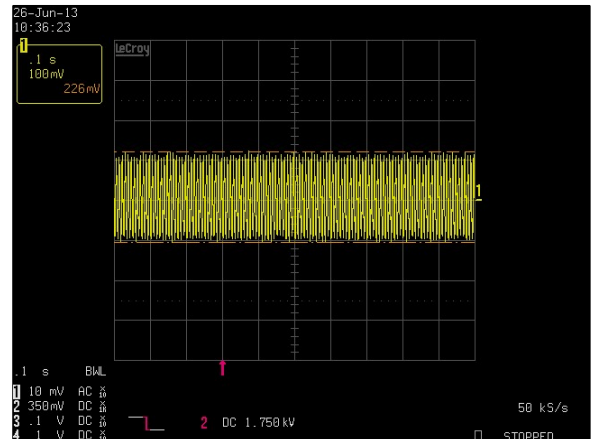

Figure 55: LCM1500U-T-4 Output Voltage Adjustment by Vprog @ 25°C
 Loading: $I_o = 0A$ (36V), $I_{SB} = 0A$ (5V)

ELECTRICAL SPECIFICATIONS

LCM1500W Performance Curves

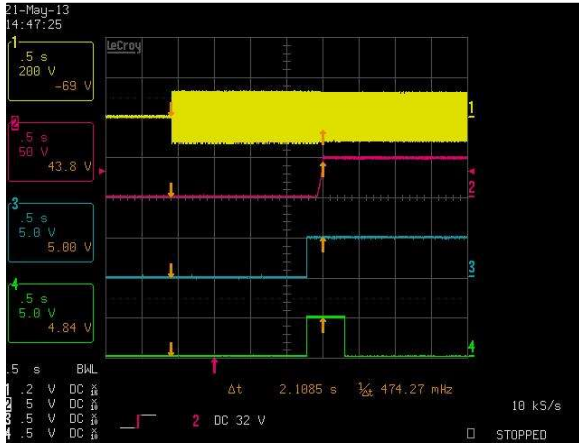

Figure 56: LCM1500W-T-4 Turn-on delay via AC mains
 Vin = 90Vac Load: lo = 32A (48V), Isb = 2A (5V)
 Ch 1: Vin Ch 2: Vsb Ch 3: Vo Ch 4: G_DCOK_C

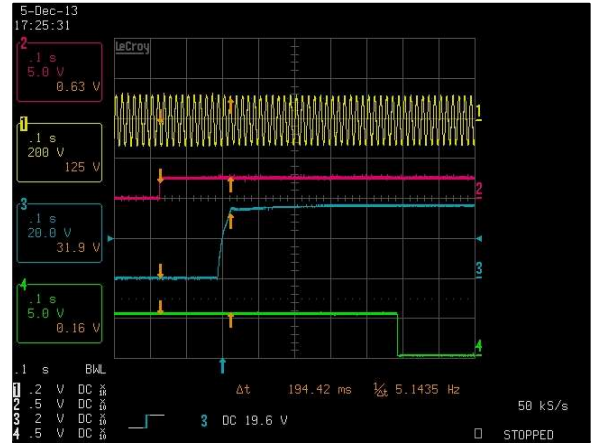

Figure 57: LCM1500W-T-4 Turn-on delay via INH_EN
 Vin = 90Vac Load: lo = 32A (48V), Isb = 2A (5V)
 Ch 1: Vin Ch 2: INH_EN Ch 3: Vo Ch 4: G_DCOK_C

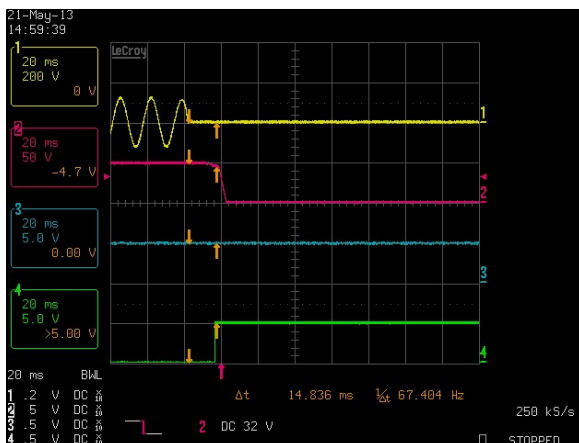

Figure 58: LCM1500W-T-4 Hold-up Time
 Vin = 90Vac / 47Hz / 0° Load: lo = 32A (48V), Isb = 2A (5V)
 Ch 1: Vin Ch 2: Vsb Ch 3: Vo Ch 4: G_DCOK_C

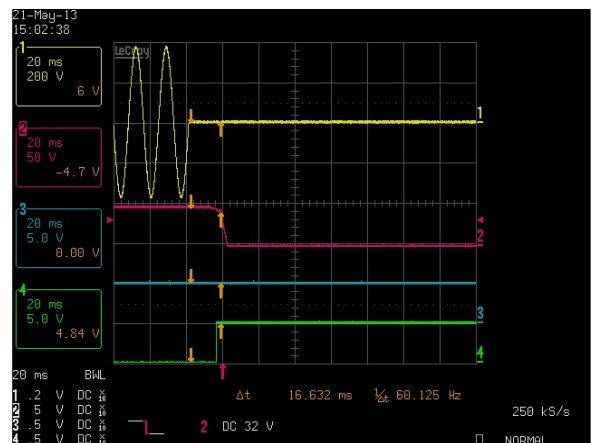

Figure 59: LCM1500W-T-4 Hold-up Time
 Vin = 264Vac / 60Hz / 0° Load: lo = 32A (48V), Isb = 2A (5V)
 Ch 1: Vin Ch 2: Vsb Ch 3: Vo Ch 4: G_DCOK_C

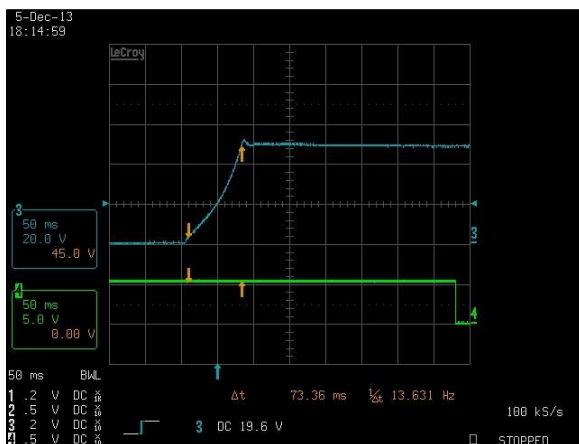

Figure 60: LCM1500W-T-4 Output Voltage Startup
 Vin = 90Vac Load: lo = 32A (48V), Isb = 2A (5V)
 Ch 3: Vo Ch 4: G_DCOK_C

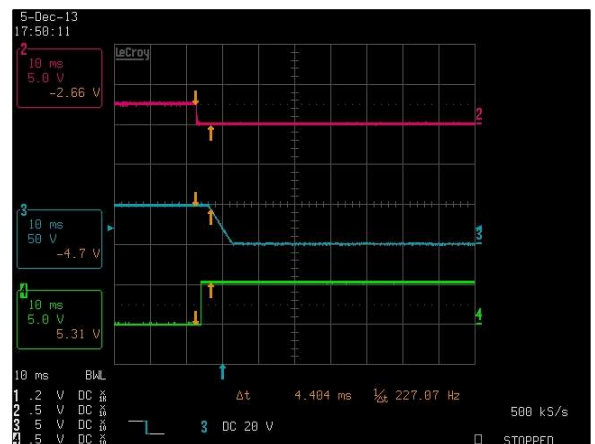

Figure 61: LCM1500W-T-4 Turn Off Characteristic via INH_EN
 Load: lo = 32A (48V), Isb = 2A (5V)
 Ch 2: INH_EN Ch 3: Vo Ch 4: G_DCOK_C

ELECTRICAL SPECIFICATIONS

LCM1500W Performance Curves

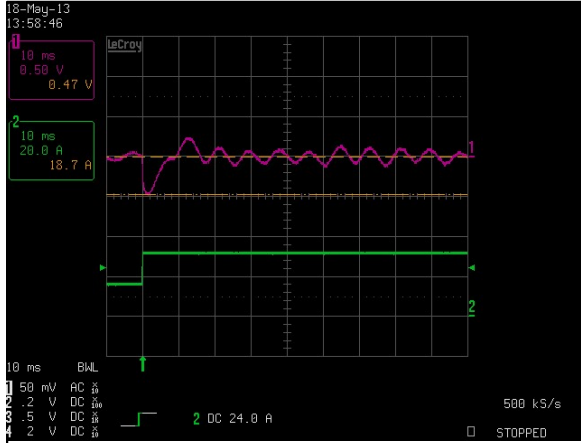

Figure 62: LCM1500W-T-4 Transient Response - Vo Deviation
50% to 100% load change 1A/uS slew rate Vin = 230Vac
Ch 1: Vo Ch 2: Io

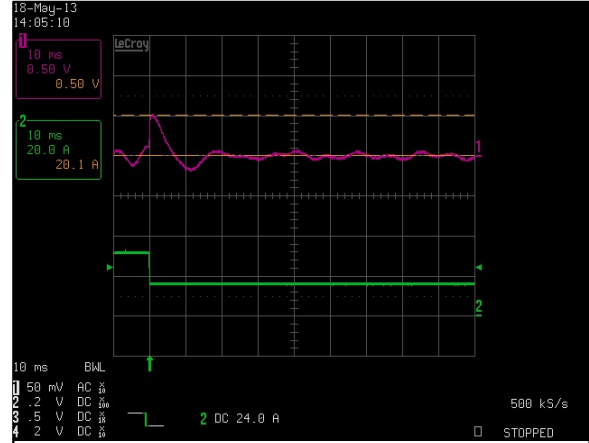

Figure 63: LCM1500W-T-4 Transient Response - Vo Deviation
100% to 50% load change 1A/uS slew rate Vin = 230Vac
Ch 1: Vo Ch 2: Io

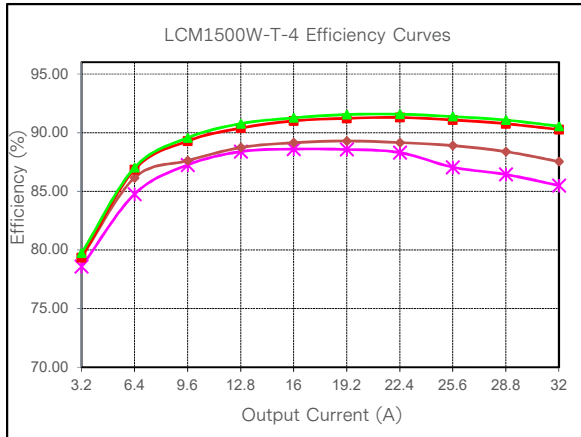

Figure 64: LCM1500W-T-4 Efficiency Curve @ 25°C
— 90Vac — 115Vac — 230Vac — 264Vac
Loading: $I_{o_main} = 10\% I_{o_max}$ increment to 32A, $I_{SB} = 0A$ (5V)

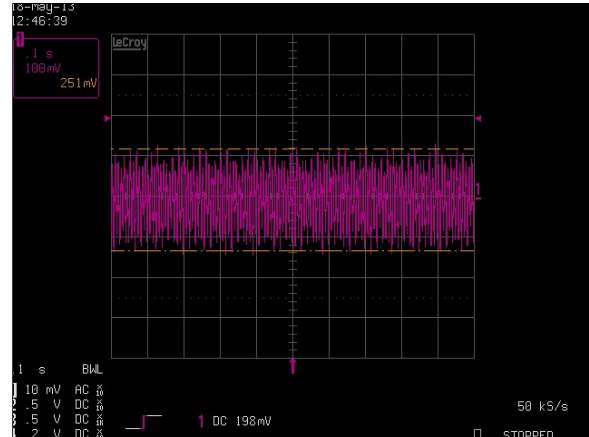

Figure 65: LCM1500W-T-4 Ripple and Noise Measurement
Vin = 115Vac Load: Io = 32A (48V), Isb = 2A (5V)
Ch 1: Vo

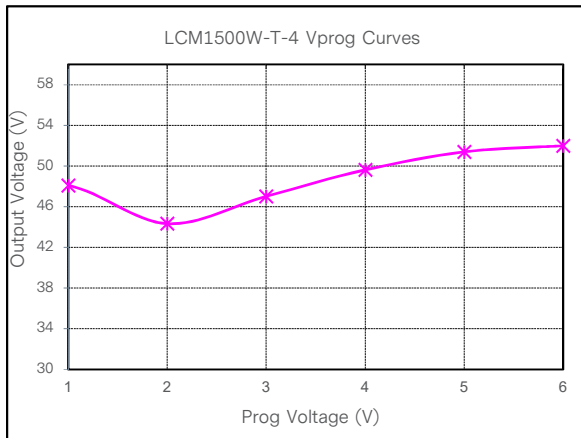

Figure 66: LCM1500W-T-4 Output Voltage Adjustment by Vprog @25°C
— 115Vac
Loading: $I_o = 0A$ (48V), $I_{SB} = 0A$ (5V)

ELECTRICAL SPECIFICATIONS

Protection Function Specifications

Input Fuse

LCM1500 series is equipped with an internal non user serviceable 30A high rupturing capacity (HRC) 250 Vac fuse to IEC 127 for fault protection in both the L1 and L2 lines input.

Over Voltage Protection (OVP)

The power supply latches off during output overvoltage with the AC line recycled to reset the latch.

Parameter	Min	Typ	Max	Unit
V _O Output Overvoltage	125	/	145	% V _O
Standby Voltage Overvoltage	110	/	125	% V _O

Over Current Protection (OCP)

LCM1500 series includes internal current limit circuitry to prevent damage in the event of overload or short circuit. Recovery is automatic when the overload is removed, the OCP is bouncing mode with a recovery time delay of 20 seconds.

Parameter	Min	Typ	Max	Unit
V _O Output Overcurrent	105	/	125	% I _{O,max}
Standby Voltage Overcurrent	120	/	170	% I _{O,max}

Short Circuit Protection (SCP)

A short circuit is defined as less than 0.03 ohm resistance between the output terminals. All outputs will be protected against short circuit to ground or other outputs. No damage will result. In the event of short circuit, output will be in bouncing mode with a recovery delay of 20Sec. Optional 5V standby, independent of the main output, will also be in bouncing mode once the fault occurred.

Over Temperature Protection (OTP)

The power supply will be internally protected against over temperature conditions. When the OTP circuit is activated, the power supply will shut off and will auto-recover once the OTP condition is gone. OTP trip-point at full Load is set at a nominal of 55 °C to 65 °C ambient temperature.

MECHANICAL SPECIFICATIONS

Mechanical Outlines (unit: mm)

LCM1500Q/R/U/W

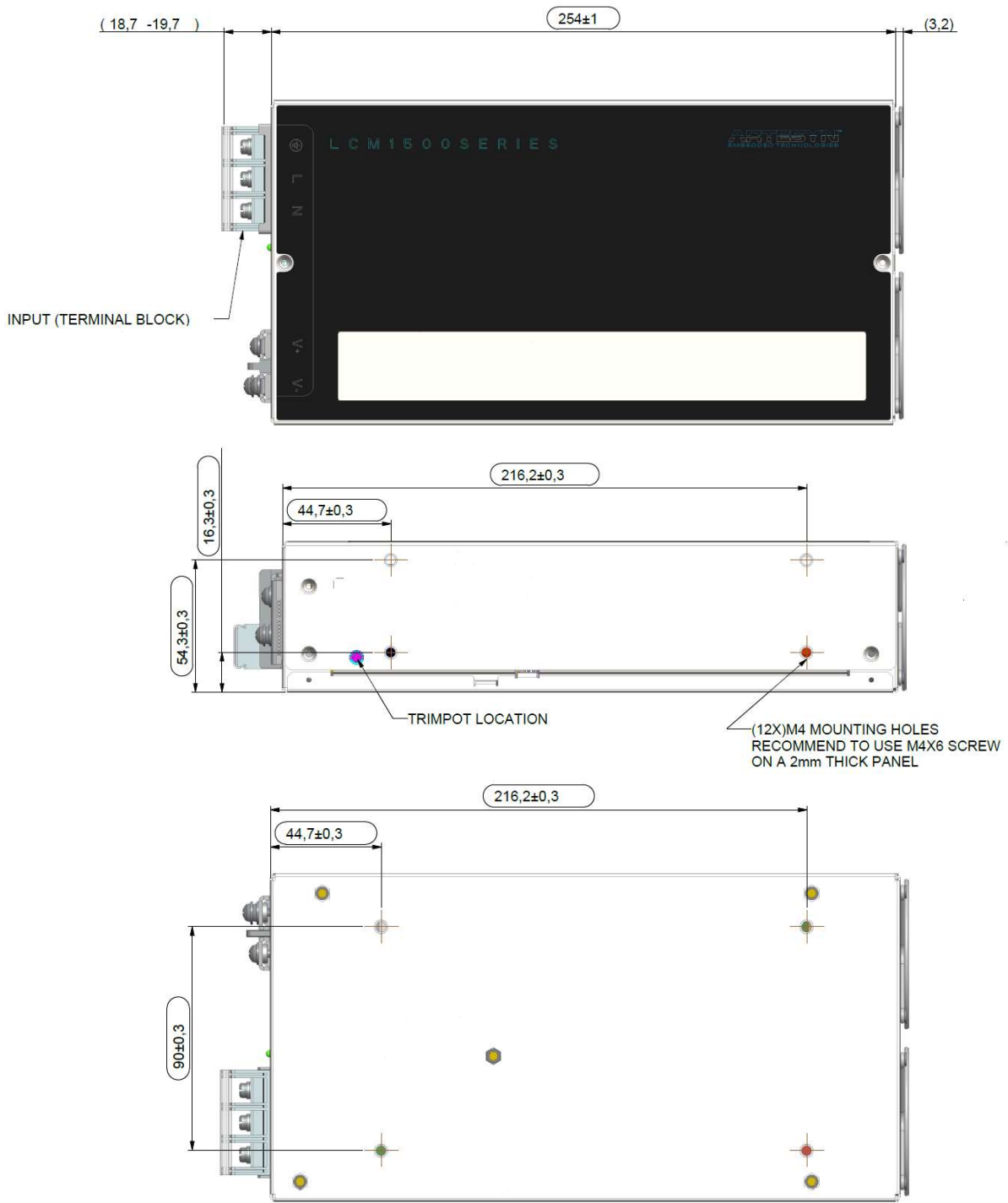

MECHANICAL SPECIFICATIONS

Mechanical Outlines (unit: mm)

LCM1500Q/R/U/W

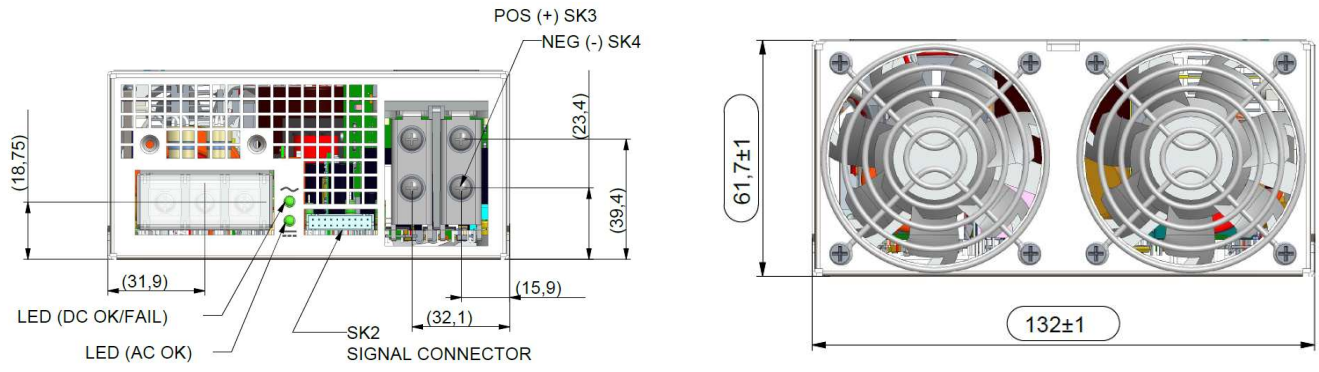

MECHANICAL SPECIFICATIONS

Mechanical Outlines (unit: mm)

LCM1500L/N

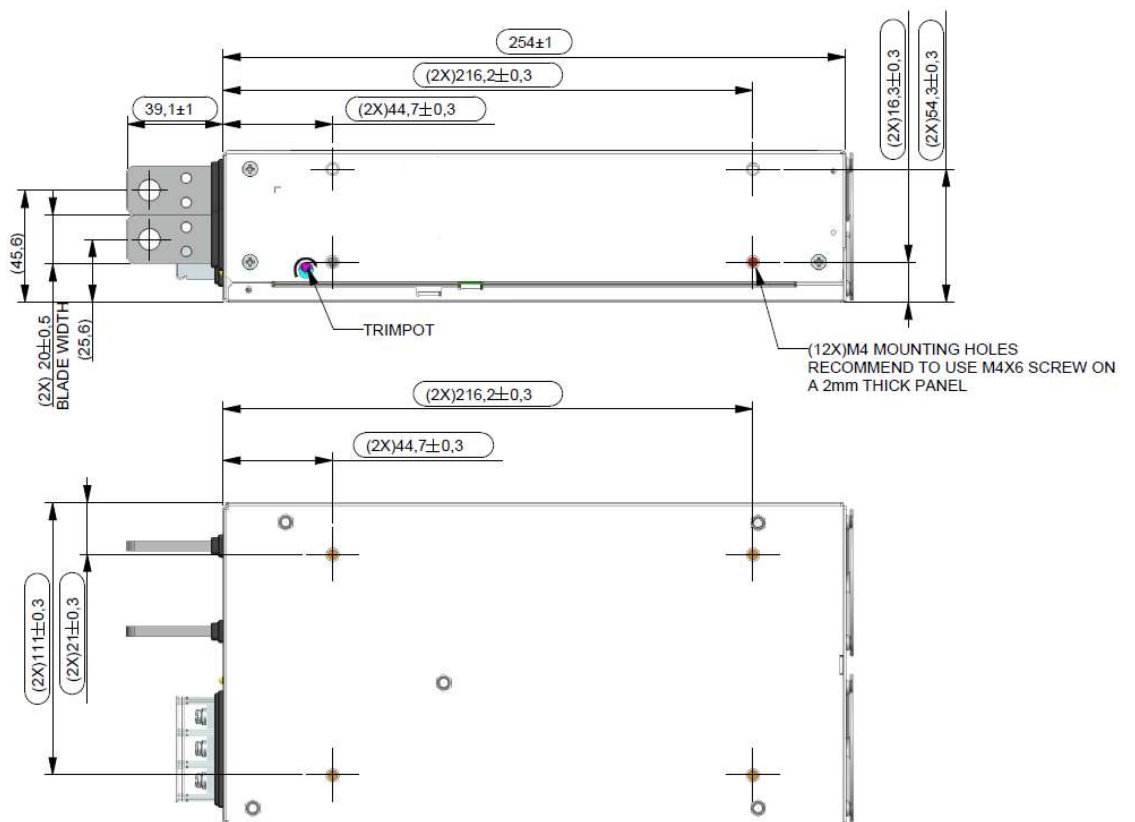
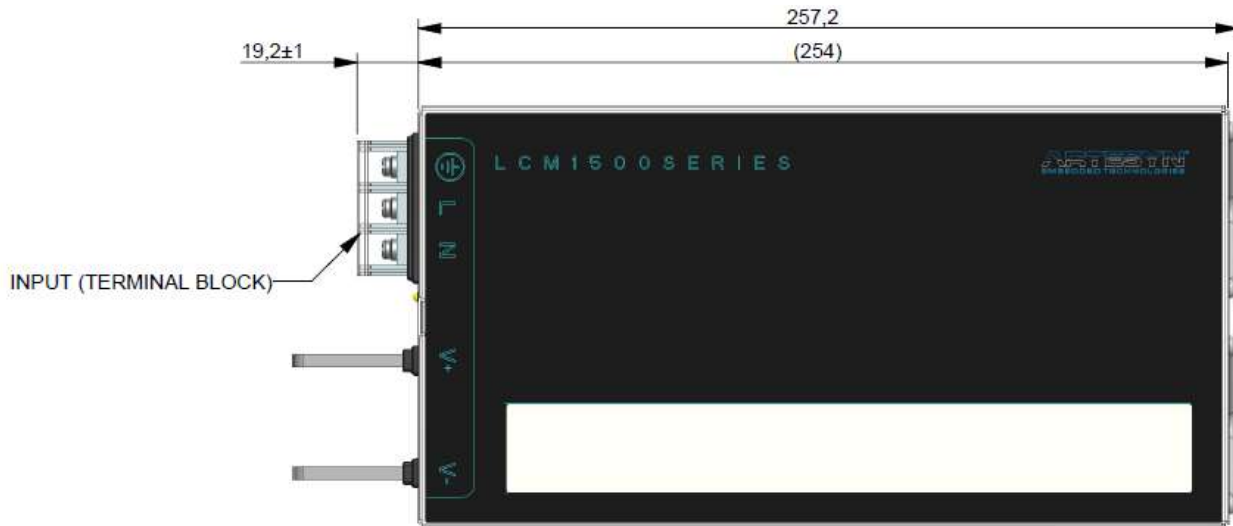

MECHANICAL SPECIFICATIONS

Mechanical Outlines (unit: mm)

LCM1500L/N

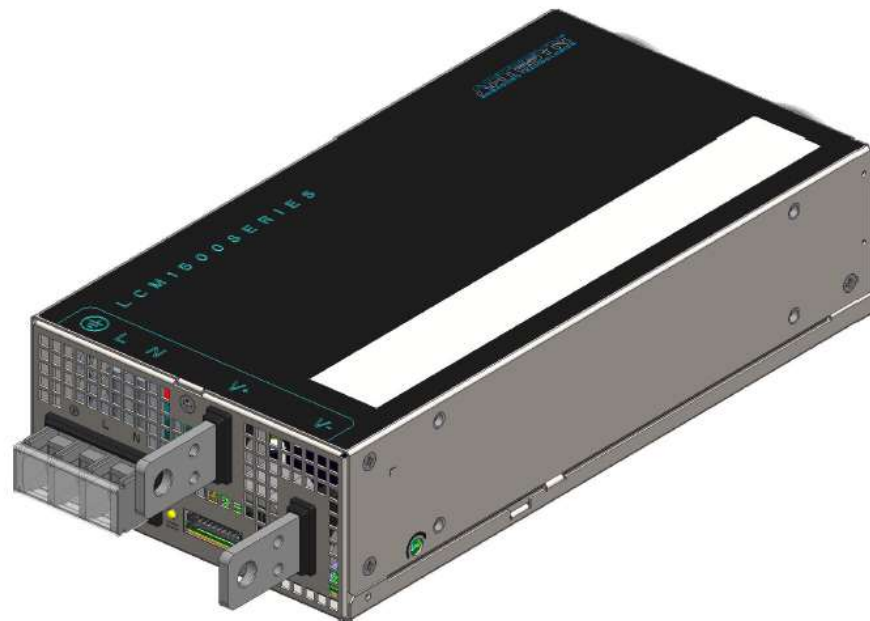
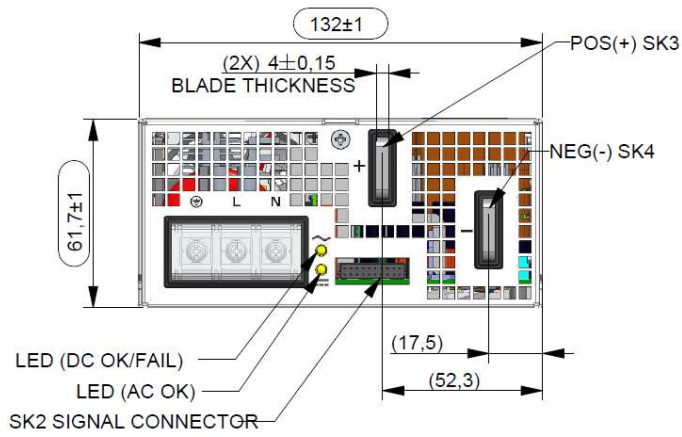

Mechanical Specifications

Connector Definitions

AC Input Connector - SK1

⊕ – Earth Ground

L – Line

N – Neutral

Output Connector – SK3&SK4

SK3 – Main Output (Vo)

SK4 – Main Output Return

Output Connector – SK2

Pin 1 – A2

Pin 2 – -VPROG

Pin 3 – A1

Pin 4 – -Vsense

Pin 5 – ISHARE

Pin 6 – A0

Pin 7 – SDA1

Pin 8 – +VPROG

Pin 9 – SCL1

Pin 10 – +Vsense

Pin 11 – 5VSB

Pin 12 – GND

Pin 13 – 5VSB

Pin 14 – G_DCOK_C

Pin 15 – GPIOA6

Pin 16 – G_DCOK_E

Pin 17 – GND

Pin 18 – G_ACOK_C

Pin 19 – INH_EN

Pin 20 – G_ACOK_E

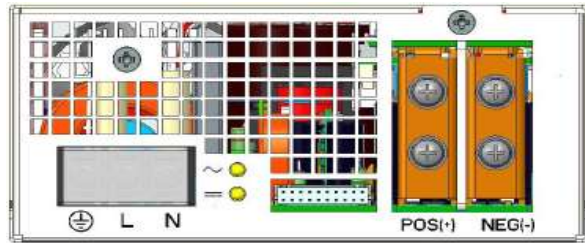

SK1

SK2

SK3

SK4

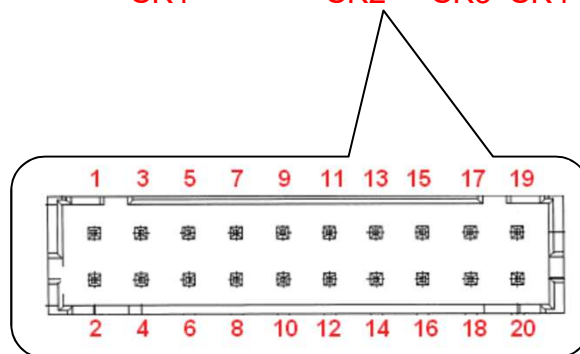

Mechanical Specifications

Power / Signal Mating Connectors and Pin Types

Table 5. Mating Connectors for LCM1500 Series		
Reference	On Power Supply	Mating Connector or Equivalent
AC Input Connector	451-004155-0000 (TERM-BLOCK DT-7C-B14W-03)	M4 Screw
SK2	CI0120P1HD0-LF	LANDWIN (LWE PN: 2050S) Housing (LWE PN: 2053T) Contact CVILUX (CX PN: CI0120SD000) Housing (CX PN: CI01TD21PE0) Contact
SK3, SK4	For LCM1500Q/R/U/W 500-004305-0000 For LCM1500L/N 500-007008-0001	For LCM1500Q/R/U/W Molex: BB-124-08 (19141-0058) M4 screw For LCM1500L/N Clearance hole diameter $\phi 8.5$

Accessories for SK2:

1. Order kit part number 73-788-001 for control connector interface with .3m wires attached

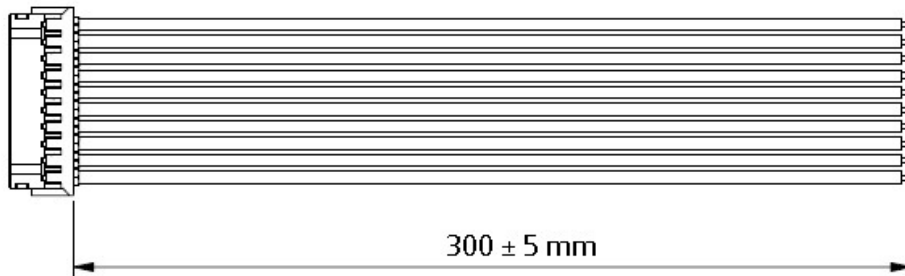

2. Order kit part number 73-788-002 for control connector interface with unloaded housing and 20 pins

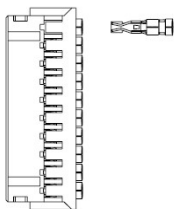

MECHANICAL SPECIFICATIONS

LED Indicator Definitions

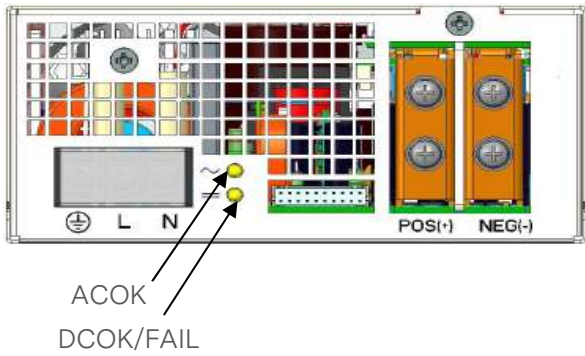

Two user-friendly LEDs for status and diagnostics show status of input power, output power and alarm condition valuable troubleshooting aid to reduce system downtime.

Conditions	LED Status	
	ACOK LED	DCOK/FAIL LED
AC present / Output On	Green	Green
No AC power to PSU	OFF	OFF
Standby mode/main output off	Green	OFF
Power supply failure	Green	OFF

MECHANICAL SPECIFICATIONS

Weight

The LCM1500 series weight is 4.20lbs (1.91kg) maximum.

ENVIRONMENTAL SPECIFICATIONS

EMC Immunity

The LCM1500 series are designed to meet the following EMC immunity specifications

Table 6. Environmental Specifications	
Document	Description
EN55032	Conducted and radiated EMI limits
EN61000-3-2 harmonic	EMC limits for harmonic current emissions
EN61000-3-3	Voltage fluctuations
EN61000-4-2	Electromagnetic Compatibility (EMC) - Testing and measurement techniques – Electrostatic discharge immunity test. +/-8KV air, +/-15KV contact discharge, Level 3
EN61000-4-3	Electromagnetic Compatibility (EMC) - Testing and measurement techniques, Radiated, radio-frequency, electromagnetic field immunity test. 80 – 1000 MHz,10V/m, AM 80% (1KHz),900MHz, 10V/M, PM100%(200Hz), Level 3
EN61000-4-4	Electromagnetic Compatibility (EMC) - Testing and measurement techniques, Electrical Fast Transient/Burst Immunity Test. 2KV for AC power port, 1.0KV for DC ports, I/O and signal ports, Level 3
EN61000-4-5	Electromagnetic Compatibility (EMC) - Testing and measurement techniques – 2KV common mode and 1KV differential mode for AC ports and 0.5kV differential mode for DC power, I/O and signal ports, Level 3
EN61000-4-8	Power Freq Magnetic, Level 3.
EN61000-4-11	Electromagnetic Compatibility (EMC) - Testing and measurement techniques : Voltage Dips and Interruptions: 30% reduction for 500mS- Criteria B>95% reduction for 10mS, Criteria A, >95% reduction for 5000mS, Level 3
EN55024: 1998	Information Technology Equipment – Immunity Characteristics, Limits and Method of Measurement

ENVIRONMENTAL SPECIFICATIONS

Safety Certifications

The LCM1500 series are intended for inclusion in other equipment and the installer must ensure that it is in compliance with all the requirements of the end application. This product is only for inclusion by professional installers within other equipment and must not be operated as a standard alone product.

Table 7. Safety Certifications for LCM1500 Series Power Supply System		
Standard	File#	Description
UL 62368-1, 2nd Ed, 2014-12-01, CAN/CSA C22.2 No. 62368-1-14, 2nd Ed	E186249-A6046-UL-X10	US and Canada Requirements
ANSI/AAMI ES60601-1 (2005/(R) 2012 +A1:2012, C1: 2009/(R) 2012 + A2:2010/(R) 2012)	E182560-V4-S5	US and Canada Medical Electrical Equipment
ANSI/AAMI ES60601-1 (2005 + C1:09 + A2:10, CAN/CSA-C22.2 No. 60601-1 (2008)	E182560-A37-UL	US and Canada Medical Electrical Equipment
EN 62368-1:2014/A11:2017, EN 60601-1:2006/A1:20163268-1	B 013890 3163 Rev. 00	European Requirements
IEC62368-1/EN63268-1	E186249-A6046-CB-1	International Requirements
IEC60601	SG-MD-00487A1/M2	International Medical Electrical Equipment
IEC60601-1/EN60601-1	211-400848-201	European and International Electrical Equipment
CB Certificate and Report	DK-48584-A2-UL	(All CENELEC Countries)
CE (LVD+RoHS),EN62368-1	20022	European Requirements
BSMI	CI333161602465 01	Taiwan Requirements
UKCA Mark		UK Requirements

ENVIRONMENTAL SPECIFICATIONS

EMI Emissions

The LCM1500 series has been designed to comply with the Class A limits of EMI requirements of EN55022 (FCC Part 15) and CISPR 32 (EN55022) for emissions and relevant sections of EN61000 (IEC 61000) for immunity. The unit is enclosed inside a metal box, tested at 1500W using resistive load with cooling fan.

Conducted Emissions

The applicable standard for conducted emissions is EN55022 (FCC Part 15). Conducted noise can appear as both differential mode and common mode noise currents. Differential mode noise is measured between the two input lines, with the major components occurring at the supply fundamental switching frequency and its harmonics. Common mode noise, a contributor to both radiated emissions and input conducted emissions, is measured between the input lines and system ground and can be broadband in nature.

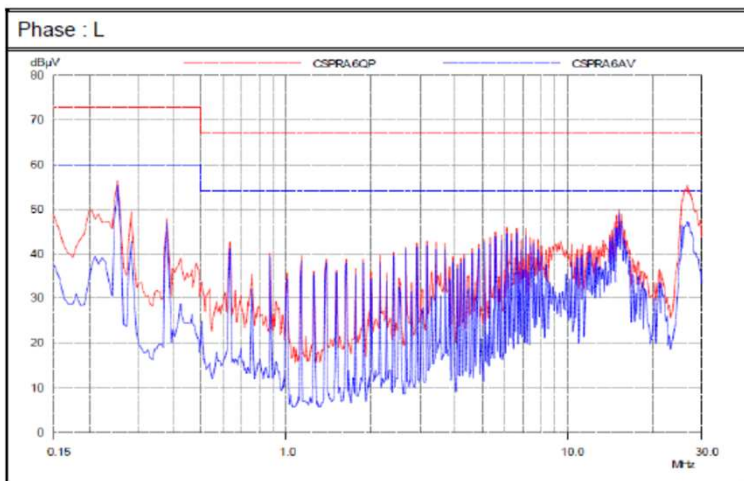

The LCM1500 series have internal EMI filters to ensure the converters' conducted EMI levels comply with EN55022 (FCC Part 15) Class A.

The EMI measurements are performed with resistive loads at maximum rated loading Sample of EN55022 Conducted EMI Measurement at 110Vac input.

Note: Red Line refers to Artesyn Quasi Peak margin, which is 6dB below the CISPR international limit. Pink Line refers to the Artesyn Average margin, which is 6dB below the CISPR international limit.

Conducted EMI emissions specifications of the LCM1500 series:

Parameter	Model	Symbol	Min	Typ	Max	Unit
FCC Part 15, class A	All	Margin	6	-	-	dB
CISPR 22 (EN55022), class A	All	Margin	6	-	-	dB

ENVIRONMENTAL SPECIFICATIONS

Radiated Emissions

Unlike conducted EMI, radiated EMI performance in a system environment may differ drastically from that in a stand-alone power supply. The shielding effect provided by the system enclosure may bring the EMI level from Class A to Class B. It is thus recommended that radiated EMI be evaluated in a system environment. The applicable standard is EN55022 Class A (FCC Part 15). Testing ac-dc convertors as a stand-alone component to the exact requirements of EN55022 can be difficult, because the standard calls for 1m leads to be attached to the input and outputs and aligned such as to maximize the disturbance. In such a set-up, it is possible to form a perfect dipole antenna that very few AC-DC convertors could pass. However, the standard also states that an attempt should be made to maximize the disturbance consistent with the typical application by varying the configuration of the test sample.

ENVIRONMENTAL SPECIFICATIONS

Operating Temperature

The LCM1500 series maximum output power (1500W) can be loaded up to an ambient temperature of +50 °C.

Only 50 % of the maximum output power can be loaded at ambient temperature of +70 °C. Linear derating to 50% nominal output power starts from +50 °C. The elapsed time between the application of input power and the attainment steady state values requires 5 minute warm up for -20 °C to -40 °C operation.

Output power vs operating temperature

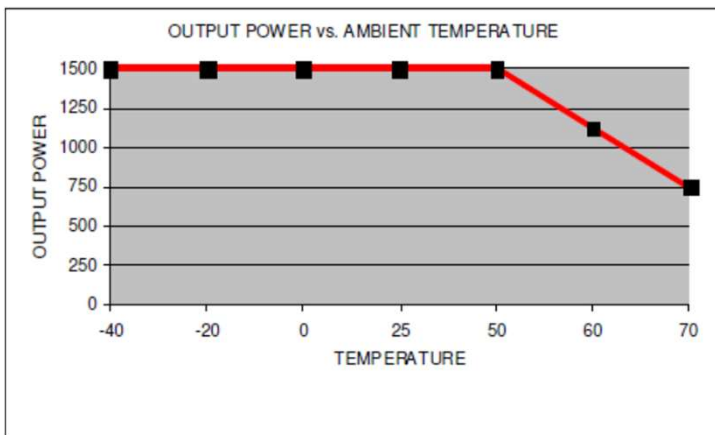

Forced Air Cooling

The LCM1500 series power supplies included internal cooling fans as part of the power supply assembly to provide forced air-cooling to maintain and control temperature of devices and ambient. The standard direction of airflow is from the end of the power supply.

The cooling fan is a variable speed fan. Fan will be smart based on internal temperature. Fan noise <45 dBA with 80% load @ 30°C.

Note: LCM1500L noise is <61dB at 80% load @ 25°C.

ENVIRONMENTAL SPECIFICATIONS

Storage and Shipping Temperature

The LCM1500 series can be stored or shipped at temperatures between -40°C to +85°C and relative humidity from 20% to 95% non-condensing.

Altitude

The LCM1500 series will operate within specifications at altitudes up to 16404 feet above sea level. The power supply will not be damaged when stored at altitudes of up to 30,000 above sea level.

Humidity

The LCM1500 series will operate within specifications when subjected to a relative humidity from 20% to 90% non-condensing. The LCM1500 series can be stored in a relative humidity from 10% to 95% non-condensing.

Vibration

The LCM1500 series will pass the following vibration specifications:

Non-Operating Random Vibration

Acceleration	2.7	gRMS	
Frequency Range	10-2000	Hz	
Duration	20	Mins	
Direction	3 mutually perpendicular axis		
PSD Profile	FREQ (Hz)	SLOPE (db/oct)	PSD (g ² /Hz)
	10	/	0.009
	200	-2.66	0.009
	500	/	0.004

Operating Random Vibration

Acceleration	1.0	gRMS	
Frequency Range	10 – 500	Hz	
Duration	20	Mins	
Direction	3 mutually perpendicular axis		
PSD Profile	FREQ (Hz)	SLOPE (db/oct)	PSD (g ² /Hz)
	5	11	0.00003
	10-50	/	0.00004
	100	-10	0.00003

ENVIRONMENTAL SPECIFICATIONS

Shock

The LCM1500 series power supply will pass the following shock specifications:

Non-Operating Half-Sine Shock

Acceleration	30	G
Duration	18	mSec
Pulse	Half-Sine	
Number of Shock	3 shock on each of 6 faces	

Operating Half-Sine Shock

Acceleration	4	G
Duration	22	mSec
Pulse	Half-Sine	
Number of Shock	3 shocks in each of 6 faces	

POWER AND CONTROL SIGNAL DESCRIPTIONS

AC Input Connector

This connector supplies the AC Mains to the LCM1500 series power supply.

- SK1 – Earth Ground
- SK1 – Line
- SK1 – Neutral

Output Connectors- SK3&SK4

These pins provide the main output for the LCM1500 series. The + Main Output (V_O) and the Main Output Return pins are the positive and negative rails, respectively, of the V_O main output of the LCM1500 series power supply. The Main Output (V_O) is electrically isolated from the power supply chassis.

- SK3 – +Main Output (V_O)
- SK4 – Main Output Return

Control Signals - SK2

The LCM1500 series SK2 contains 20 pins control signal header providing analogy control interface, standby power and i²C interface.

A0, A1, A2 - (Pin 6, Pin3, Pin1)

Please refer to “Communication Bus Descriptions” section.

-VPROG, +VPROG - (Pin2, Pin8)

Positive and return connection of external supply for Margin Programming. The Power supplies will have a “margin” pin which will accept a 1-6VDC signal referenced to a floating return that will program the output the entire adjustment range. Applying voltage greater than 6V may result to damage of PSU internal circuit.

-Vsense, +Vsense - (Pin 4, Pin10)

This remote sense circuit will be designed to compensate for a power path drop around the entire loop of 0.5 volt. These pins should be connected as close to the loading as possible, If left open, the power supply will regulate the voltage at its output terminals but the voltage level at the load may go lower than the guaranteed spec.

ISHARE - (Pin 5)

The main output will have active load sharing. The output will share within 10% at full load. All current sharing functions are implemented internal to the power supply by making use of the ISHARE signal. The system connects the ISHARE lines between the power supplies. The supplies must be able to load share with up to 4 power supplies in parallel.

SDA1, SCL1, GND - (Pin 7, Pin9, Pin17)

Please refer to “Communication Bus Descriptions” section.

5VSB, GND - (Pin11, Pin12, Pin13)

The LCM1500 series provides a regulated 5VSB output voltage to power critical circuitry that must remain active regardless of the on/off status of the power supply’s main output. The 5VSB voltage is available whenever a valid AC input voltage is applied to the unit.

POWER AND CONTROL SIGNAL DESCRIPTIONS

G_DCOK_C, G_DCOK_E - (Pin14, Pin16)

G_DCOK_C is a power good signal and will be pulled LOW by the power supply to indicate that both the outputs are above the regulation limits of the power supply. When any output voltage falls below regulation limits or when AC power has been removed for a time sufficiently long so that power supply operation is no longer guaranteed, G_DCOK_C will be de-asserted to a HIGH state. Connect 4.7K ohm resistor on G_DCOK_C to PSU's 5V standby.

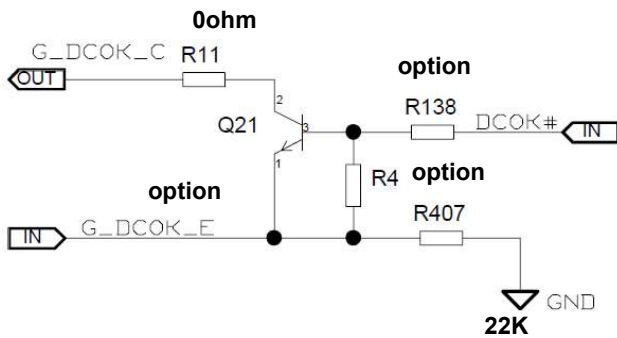

GPIOA6 - (Pin15)

EEPROM Write Protect Allows Read/Write operation when connected to Gnd. When GPIOA6 pin is connected to 3.3V, the write protection is enabled.

G_ACOK_C, G_ACOK_E - (Pin18, Pin20)

G-ACOK_C signal is used to indicate presence of AC input to the power supply. A logic “Low” level on this signal shall indicate AC input to the power supply is present. A Logic “High” on this signal shall indicate a loss of AC input to the power supply. Connect 4.7K ohm resistor on G_ACOK_C to 5V standby.

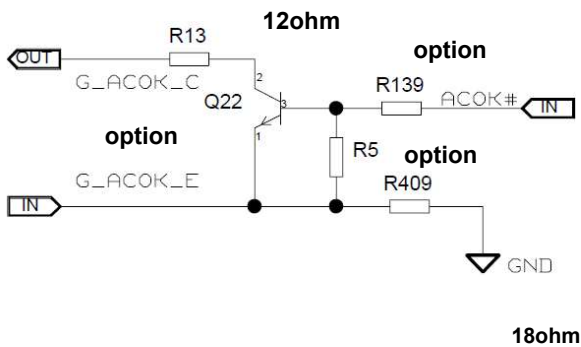

INH_EN - (Pin19)

0.0 - 0.5V contact closure. Main output is disabled if INH_EN is pulled low.

COMMUNICATION BUS DESCRIPTIONS

I²C Bus Signals

The LCM1500 series contains enhanced monitor and control functions implemented via the I²C bus. The LCM1500 series I²C functionality (PMBus™ and FRU data) can be accessed via the output connector control signals. The communication bus is powered either by the internal 3.3V supply or from an external power source connected to the standby output (ie: accessing an unpowered power supply as long as the standby output of another power supply connected in parallel is on).

If units are connected in parallel or in redundant mode, the standby outputs must be connected together in the system. Otherwise, the I²C bus will not work properly when a unit is inserted into the system without the AC source connected.

Note: PMBus™ functionality can be accessed only when the PSU is powered-up. Guaranteed communication I²C speed is 100KHz.

SDA1, SCL1 (I²C Data and Clock Signals) - (pin7, pin 9)

I²C serial data and clock bus - these pins are internally pulled up to internal 3.3V supply with a 4.7K ohm resistor. These pins recommended to be pulled-up in the system by an 2.2K ohm resistor to the 3.3V external voltage.

A0, A1, A2 (I²C Address BIT 0, BIT1, BIT2 Signals) - (pin6, pin3, pin1)

These three input pins are the address lines A0, A1 and A2 to indicate the slot position the power supply occupies in the power bay and define the power supply addresses for FRU data and PMBus™ data communication. This allows the system to assign different addresses for each power supply. During I²C communication between system and power supplies, the system will be the master and power supplies will be slave.

They are internally pulled up to internal 3.3V supply with a 2K ohm resistor.

I²C Bus Communication Interval

The interval between two consecutive I²C communications to the power supply should be at least 50ms to ensure proper monitoring functionality.

I²C Bus Signal Integrity

The noise on the I²C bus (SDA, SCL lines) due to the power supply will be less than 450mV peak-to-peak. This noise measurement should be made with an oscilloscope bandwidth limited to 100MHz. Measurements should be made at the power supply output connector with 2.2K ohm resistors pulled up to standby Output and 20pf ceramic capacitors to standby output Return.

The noise on the address lines A0 and A1 will be less than 100mV peak-to-peak. This noise measurement should be made at the power supply output connector.

COMMUNICATION BUS DESCRIPTIONS

I²C Bus Internal Implementation, Pull-ups and Bus Capacitances

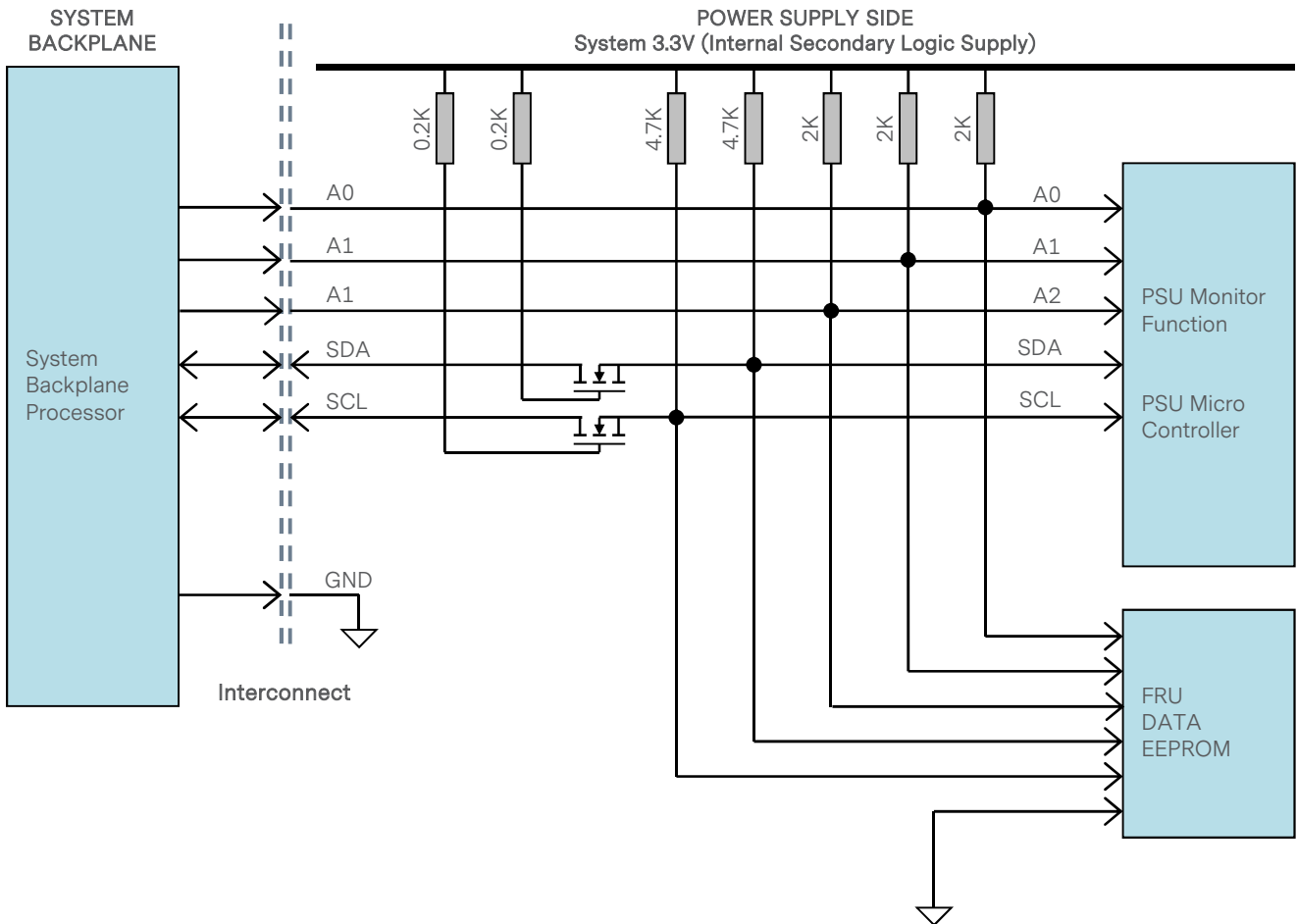

I²C Bus - Recommended external pull-ups

Electrical and interface specifications of I²C signals (referenced to standby output return pin, unless otherwise indicated):

Parameter	Condition	Symbol	Min	Type	Max	Unit
SDA, SCL Internal Pull-up Resistor		R_{int}	-	4.7	-	Kohm
SDA, SCL Internal Bus Capacitance		C_{int}	-	0	-	pF
Recommended External Pull-up Resistor	1 to 4 PSU	R_{ext}	-	2.2	-	Kohm

COMMUNICATION BUS DESCRIPTIONS

Device Addressing

The LCM1500 series will respond to supported commands on the I²C bus that are addressed according to pins A0, A1 and A2 of output connector.

Address pins are held HIGH by default via pulled up to internal 3.3V supply with a 2K resistor. To set the address as “0”, the corresponding address line should be pulled down to logic ground level. Below tables show the address of the power supply with A0, A1 and A2 pins set to either “0” or “1”:

PSU Slot	Slot ID Bits			PMBus™ Address
	A2	A1	A0	
1	0	0	0	B0h
2	0	0	1	B2h
3	0	1	0	B4h
4	0	1	1	B6h
5	1	0	0	B8h
6	1	0	1	Bah
7	1	1	0	BCh
8	1	1	1	BEh*

* Default PMBus™ address is BEh

COMMUNICATION BUS DESCRIPTIONS

Logic Levels

LCM1500 series power supply I²C communication bus will respond to logic levels as per below:

Logic High: 5.1V nominal (Spec is 2.1V to 5.5V)**

Logic Low: 500mV nominal (Spec is 800mV max)**

**Note: Artesyn 73-769-001 I²C adapter was used.

Timings

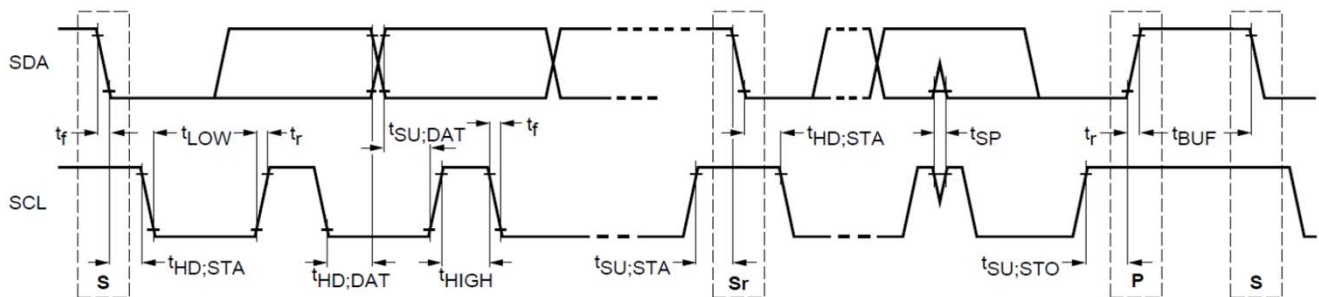

Parameter	Symbol	Standard-Mode Specs		Actual Measured		Unit
		Min	Max			
SCL clock frequency	f_{SCL}	10	100	98		KHz
Hold time (repeated) START condition	$t_{HD;STA}$	4.0	-	4.5		uS
LOW period of SCL clock	t_{LOW}	4.7	-	5.9		uS
HIGH period of SCL clock	t_{HIGH}	4.0	-	4.3		uS
Setup time for repeated START condition	$t_{SU;STA}$	4.7	-	4.5		uS
Data hold time	$t_{HD;DAT}$	0	3.45	1.2		uS
Data setup time	$t_{SU;DAT}$	250	-	4500		nS
Rise time	t_r	-	1000	SCL = 850	SDA = 903	nS
Fall time	t_f	-	300	SCL = 298	SDA = 590	nS
Setup time for STOP condition	$t_{SU;STO}$	4.0	-	5.2		uS
Bus free time between a STOP and START condition	t_{BUF}	4.7	-	60***		uS

***Note: Artesyn 73-769-001 I²C adapter (USB-to-I2C) and Universal PMBus™ GUI software was used.

COMMUNICATION BUS DESCRIPTIONS

I²C Synchronization

The LCM1500 series power supply might apply clock stretching. An addressed slave power supply may hold the clock line (SCL) low after receiving (or sending) a byte, indicating that it is not yet ready to process more data. The system master that is communicating with the power supply will attempt to raise the clock to transfer the next bit, but must verify that the clock line was actually raised. If the power supply is clock stretching, the clock line will still be low (because the connections are open-drain).

The maximum time-out condition for clock stretching for LCM1500 series is 25 milliseconds.

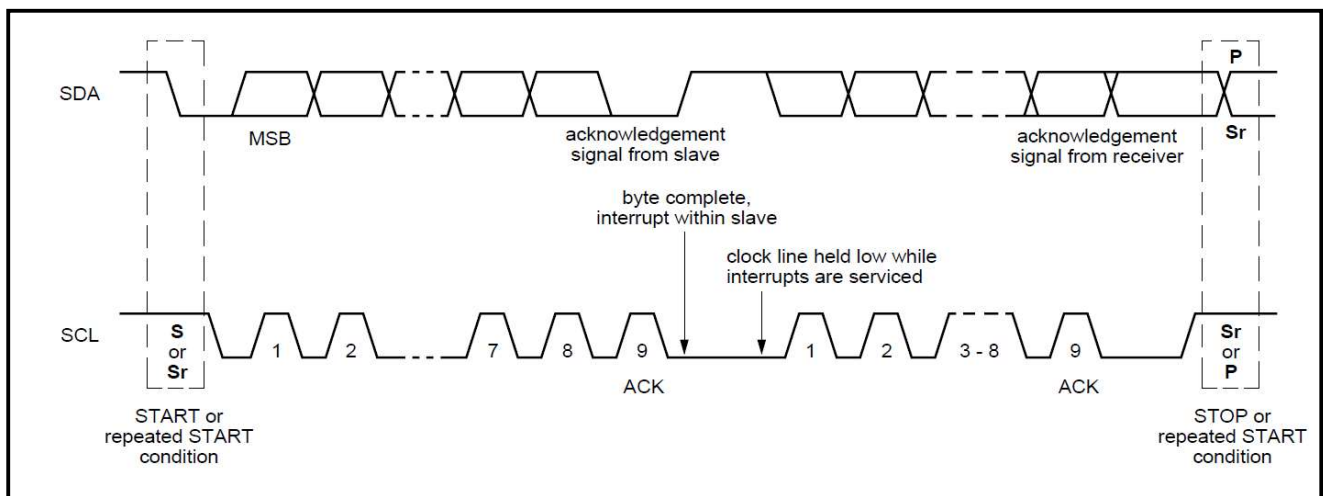

PMBUS™ SPECIFICATIONS

The LCM1500 series is compliant with the industry standard PMBus™ protocol for monitoring and control of the power supply via the I²C interface port.

LCM1500 Series PMBus™ General Instructions

Equipment Setup

The following is typical I²C communication setup:

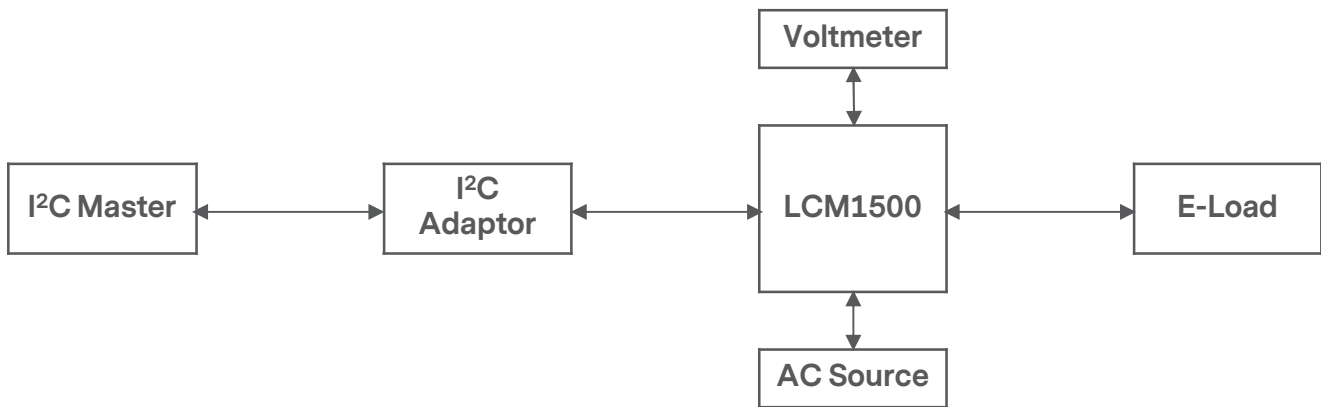

PMBus™ Writing Instructions

When writing to any PMBus™ R/W registers, ALWAYS do the following:

Disable Write Protect (command 10h) by writing any of the following accordingly:

Levels: 00h - Enable writing to all writeable commands

20h - Disables write except 10h, 01h, 00h, 02h and 21h commands

40h - Disables write except 10h, 01h, and 00h commands

80h - Disable write except 0x00h

To save changes on the USER PMBus™ Table:

Use send byte command: 15h STORE_USER_ALL

Wait for 5 seconds, turn-off the PSU, wait for another 5 seconds before turning it on.

PMBUS™ SPECIFICATIONS

The LCM1500L Series Supported PMBus™ Command List:

Command Code	Command Name	Default Value	Access Type	Data Bytes	Data Format	Description
01h	OPERATION	80	R/W	1	B	Used to turn the unit ON/OFF in conjunction with the input INH_EN pin.
02h	ON_OFF_CONFIG	1E	R	1	B	Configures the combination of INH_EN pin and serial communication commands needed to turn the unit ON/OFF.
03h	CLEAR_FAULTS	-	S	1		
10h	WRITE_PROTECT	80	R/W	1	MSF	Used to Control Writing to the PMBus Device 80h - Disables write except 10h 40h - Disables write except 10h, 01h, 00h 20h - Disables write except 10h,01h,00h,02h and 21h commands 00 -Enables write to all writeable commands.
15h	STORE_USER_ALL	-	S	0		Copies the Operating memory table to the matching USER non-volatile memory.
20h	VOUT_MODE	17	R	1	B	Specifies the mode and parameters of Output Voltage related Data Formats
21h	VOUT_COMMAND	1800	R/W	2	Linear	Sets the Output Voltage Reference Vout command sends discreet value to change or trim output voltage. (12V)
24h	VOUT_MAX	1A66	R	2	Linear	The max adjustable output voltage limit. (13.2V)
3Ah	FAN_CONFIG_1_2	99h	R	1	Bitmapped	Read only to reflect setting of Fans
3Bh	FAN_COMMAND_1	0	R/W	2	Linear	Adjust fan speed, duty cycle control from 0 to 100%
3Ch	FAN_COMMAND_2	0	R/W	2	Linear	Adjust fan speed, duty cycle control from 0 to 100%
40h	VOUT_OV_FAULT_LIMIT	2066	R/W	2	Linear	Sets Output Over voltage threshold. (16.2V)
41h	VOUT_OV_FAULT_RESPONSE	80	R	1	MSF	Unit Latches OFF. Resets on INH_EN or CONTROL pin recycle or AC recycle.
42h	VOUT_OV_WARN_LIMIT	1C66	R	2	Linear	Over-voltage Warning threshold. (14.2V)
43h	VOUT_UV_WARN_LIMIT	1466	R	2	Linear	Under-voltage Warning threshold. (10.2V)
44h	VOUT_UV_FAULT_LIMIT	1400	R	2	Linear	Under-voltage Fault threshold. (10V)
45h	VOUT_UV_FAULT_RESPONSE	80	R	1	MSF	Turn PSU OFF
46h	IOUT_OC_FAULT_LIMIT	F21C	R	2	Linear	Over current threshold in Amps. (135A)
47h	IOUT_OC_FAULT_RESPONSE	C0	R	1	MSF	OCP ride through. If OCP persists.
4Ah	IOUT_OC_WARN_LIMIT	EBFC	R	2	Linear	Over Current Warning threshold in Amps. (127.5A)

PMBUS™ SPECIFICATIONS

The LCM1500L Series Supported PMBus™ Command List:

Command Code	Command Name	Default Value	Access Type	Data Bytes	Data Format	Description
4Fh	OT_FAULT_LIMIT	EBB0	R	2	Linear	Secondary ambient temperature Fault threshold, in degree C. (118degC)
50h	OT_FAULT_RESPONSE	F8	R	1	MSF	Turn PSU OFF and will retry indefinitely
51h	OT_WARN_LIMIT	EA30	R	2	Linear	Secondary ambient temperature warning threshold, in degree C.(114degC)
55h	VIN_OV_FAULT_LIMIT	FA3A	R	2	Linear	Sets Input Over voltage threshold. (285V)
56h	VIN_OV_FAULT_RESPONSE	C0	R	1	Linear	Turn PSU OFF
58h	VIN_UV_WARN_LIMIT	EAB0	R	2	Linear	Sets Input Under voltage warning threshold(86V)
59h	VIN_UV_FAULT_LIMIT	EA78	R	2	Linear	Sets Input Under voltage threshold(79V)
5Ah	VIN_UV_FAULT_RESPONSE	F8	R	1	Linear	Turn PSU OFF
5Eh	POWER_GOOD_ON	1757	R	2	Linear	Sets the threshold by which the Power Good signal is asserted. (11.67V)
5Fh	POWER_GOOD_OFF	158F	R	2	Linear	Sets the threshold by which the Power Good signal is de-asserted. (10.78V)
60h	TON_DELAY	EB20	R	2	Linear	Sets the time (sec), from start condition (Power ON) until the output starts to rise. 100mS
61h	TON_RISE	DA80	R	2	Linear	Sets the time (ms), for the output rises from 0 to regulation. 20mS
64h	TOFF_DELAY	DA80	R	2	Linear	Sets the time (ms), from a stop condition (Power OFF) until the output starts to drop (converter OFF).
78h	STATUS_BYTE	00	R	1	Binary	Returns the summary of critical faults
	b7 – BUSY					A fault was declared because the device was busy and unable to respond.
	b6 – OFF					Unit is OFF
	b5 – VOUT_OV					Output over-voltage fault has occurred
	b4 – IOUT_OC					Output over-current fault has occurred
	b3 - VIN_UV					An input under--voltage fault has occurred
	b2 - TEMPERATURE					A temperature fault or warning has occurred
	b1 – CML					A communication, memory or logic fault has occurred.
	b0 – NONE OF THE ABOVE					A Fault Warning not listed in bits[7:1] has occurred.

PMBUS™ SPECIFICATIONS

The LCM1500L Series Supported PMBus™ Command List:

Command Code	Command Name	Default Value	Access Type	Data Bytes	Data Format	Description
79h	STATUS_WORD	0000	R	2	Binary	Summary of units Fault and warning status.
	b15 – VOUT					An output voltage fault or warning has occurred
	b14 – IOUT/POUT					An Output current or power fault or warning has occurred.
	b13 – INPUT					An input voltage, current or power fault or warning as occurred.
	b12 – MFR					A manufacturer specific fault or warning has occurred.
	b11 – POWER_GOOD#					The POWER_GOOD signal is de-asserted
	b10 - FANS					A fan or airflow fault or warning has occurred.
	b9 – OTHER					A bit in STATUS_OTHER is set.
	b8 – UNKNOWN					A fault type not given in bits [15:1] of the STATUS_WORD has been detected.
	b7 – BUSY					A fault was declared because the device was busy and unable to respond.
	b6 – OFF					Unit is OFF
	b5 – VOUT_OV					Output over-voltage fault has occurred
	b4 – IOUT_OC					Output over-current fault has occurred
	b3 - VIN_UV					An input under-voltage fault has occurred
	b2 – TEMPERATURE					A temperature fault or warning has occurred
	b1 – CML					A communication, memory or logic fault has occurred.
b0 – NONE_OF_THE_ABOVE					A fault or warning not listed in bits[7:1] of this byte has occurred.	
7Ah	STATUS_VOUT	00	R	1	Binary	Output voltage related faults and warnings
	b7					VOUT Over--voltage Fault
	b6					VOUT Over-voltage warning
	b5					VOUT Under-voltage Warning
	b4					VOUT Under-voltage Fault
	b3					VOUT_MAX Warning, an attempt has been made to set output to a value higher than the highest permissible voltage.
	b2					TON_MAX_FAULT
	b1					TOFF_MAX Warning
	b0					reserved

PMBUS™ SPECIFICATIONS

The LCM1500L Series Supported PMBus™ Command List:

Command Code	Command Name	Default Value	Access Type	Data Bytes	Data Format	Description
7Bh	STATUS_IOUT	00	R	1	Binary	Output Current related faults and warnings
	b7					IOUT Over current Fault
	b6					IOUT Over current And Low Voltage shutdown Fault
	b5					VOUT Under-voltage Warning
	b4					VOUT Under-voltage Fault
	b3					VOUT_MAX Warning, an attempt has been made to set output to a value higher than the highest permissible voltage.
	b2					TON_MAX_FAULT
	b1					TOFF_MAX Warning
	b0					reserved
7Dh	STATUS_TEMPERATURE	00	R	1	Binary	Temperature related faults and warnings
	b7					Over temperature Fault
	b6					Over temperature Warning
	b5					Under temperature Warning
	b4					Under temperature Fault
	b3:0					reserved
7Eh	STATUS_CML	C0	R	1	Binary	Communications, Logic and Memory
80h	STATUS_MFR_SPECIFIC	0	R	1	Binary	Manufacturer Status codes
88h	READ_VIN	-	R	2	Linear	Returns input Voltage in Volts ac
8Bh	READ_VOUT	-	R	2	Linear	Returns the actual, measured voltage in Volts.
8Ch	READ_IOUT	-	R	2	Linear	Returns the output current in amperes.
8Dh	READ_TEMPERATURE_1	-	R	2	Linear	PSU Air inlet temp (inside PSU)
8Eh	READ_TEMPERATURE_2	-	R	2	Linear	PSU Air inlet temp (inside PSU)
96h	READ_POUT	-	R	2	Linear	Returns the output power, in Watts.
97h	READ_PIN	-	R	2	Linear	Returns the input power, in Watts
99h	MFR_ID	-	R/W	8	ASCII	Artesyn
9Ah	MFR_MODEL	-	R/W	8	ASCII	LCM1500
9Bh	MFR_REVISION	-	R/W	2	ASCII	
9Ch	MFR_LOCATION	-	R/W	8	ASCII	Laguna
9Dh	MFR_DATE	-	R/W	8	ASCII	Manufacture Date, ASCII format structure : YYYYMMDD
9Eh	MFR_SERIAL	-	R/W	13	ASCII	13 CHAR

PMBUS™ SPECIFICATIONS

The LCM1500L Series Supported PMBus™ Command List:

Command Code	Command Name	Default Value	Access Type	Data Bytes	Data Format	Description
A0h	MFR_VIN_MIN	EAD0	R	2	Linear	Minimum Input Voltage (90Vac)
A1h	MFR_VIN_MAX	FA10	R	2	Linear	Maximum Input Voltage (264Vac)
A2h	MFR_IIN_MAX	DA60	R	2	Linear	Maximum Input Current (19A)
A4h	MFR_VOUT_MIN	1599	R	2	Linear	Minimum Output Voltage Regulation Window. (10.8V)
A5h	MFR_VOUT_MAX	1A66	R	2	Linear	Maximum Output Voltage. Regulation Window (13.2V)
A6h	MFR_IOUT_MAX	EBE8	R	2	Linear	Maximum Output Current (125A)
A7h	MFR_POUT_MAX	-	R	2	Linear	Maximum Output Power (1560W)
A8h	MFR_TAMBIENT_MAX	EA30	R	2	Linear	Maximum Operating Ambient Temperature (Secondary Ambient) (70 degC)
A9h	MFR_TAMBIENT_MIN	-	R	2	Linear	Minimum Operating Ambient Temperature (Secondary Ambient) (-40 degC)
E0h	FW_PRI_VERSION	-	BR	8	ASCII	Varies
E1h	FW_SEC_VERSION	-	BR	8	ASCII	Varies

PMBUS™ SPECIFICATIONS

The LCM1500Q Series Supported PMBus™ Command List:

Command Code	Command Name	Default Value	Access Type	Data Bytes	Data Format	Description
01h	OPERATION	80	R/W	1	B	Used to turn the unit ON/OFF in conjunction with the input INH_EN pin.
02h	ON_OFF_CONFIG	1E	R	1	B	Configures the combination of INH_EN pin and serial communication commands needed to turn the unit ON/OFF.
03h	CLEAR_FAULTS	-	S	1		
10h	WRITE_PROTECT	80	R/W	1	MSF	Used to Control Writing to the PMBus Device 80h - Disables write except 10h 40h - Disables write except 10h, 01h, 00h 20h - Disables write except 10h,01h,00h,02h and 21h commands 00 -Enables write to all writeable commands.
15h	STORE_USER_ALL	-	S	0		Copies the Operating memory table to the matching USER non-volatile memory.
20h	VOUT_MODE	17	R	1	B	Specifies the mode and parameters of Output Voltage related Data Formats
21h	VOUT_COMMAND	3000	R/W	2	Linear	Sets the Output Voltage Reference Vout command sends discreet value to change or trim output voltage.
24h	VOUT_MAX	34CC	R	2	Linear	The max adjustable output voltage limit. 26.4V
3Ah	FAN_CONFIG_1_2	99h	R	1	Bitmapped	Read only to reflect setting of Fans
3Bh	FAN_COMMAND_1	0	R/W	2	Linear	Adjust fan speed, duty cycle control from 0 to 100%
3Ch	FAN_COMMAND_2	0	R/W	2	Linear	Adjust fan speed, duty cycle control from 0 to 100%
40h	VOUT_OV_FAULT_LIMIT	40CC	R/W	2	Linear	Sets Output Over voltage threshold. (31V)
41h	VOUT_OV_FAULT_RESPONSE	80	R	1	MSF	Unit Latches OFF. Resets on INH_EN or CONTROL pin recycle or AC recycle.
42h	VOUT_OV_WARN_LIMIT	35DC	R	2	Linear	Over-voltage Warning threshold. (30V)
43h	VOUT_UV_WARN_LIMIT	28CC	R	2	Linear	Under-voltage Warning threshold. (18V)
44h	VOUT_UV_FAULT_LIMIT	2800	R	2	Linear	Under-voltage Fault threshold. (15V)
45h	VOUT_UV_FAULT_RESPONSE	80	R	1	MSF	Turn PSU OFF
46h	IOUT_OC_FAULT_LIMIT	EA18	R	2	Linear	Over current threshold in Amps. (67A)
47h	IOUT_OC_FAULT_RESPONSE	C0	R	1	MSF	OCP ride through. If OCP persists.
4Ah	IOUT_OC_WARN_LIMIT	EA03	R	2	Linear	Over Current Warning threshold in Amps. (64.4A)

PMBUS™ SPECIFICATIONS

The LCM1500Q Series Supported PMBus™ Command List:

Command Code	Command Name	Default Value	Access Type	Data Bytes	Data Format	Description
4Fh	OT_FAULT_LIMIT	EB80	R	2	Linear	Secondary ambient temperature Fault threshold, in degree C. (80degC)
50h	OT_FAULT_RESPONSE	F8	R	1	MSF	Turn PSU OFF and will retry indefinitely
51h	OT_WARN_LIMIT	EA30	R	2	Linear	Secondary ambient temperature warning threshold, in degree C. (108degC)
55h	VIN_OV_FAULT_LIMIT	FA3A	R	2	Linear	Sets Input Over voltage threshold. (285V)
56h	VIN_OV_FAULT_RESPONSE	C0	R	1	Linear	Turn PSU OFF
58h	VIN_UV_WARN_LIMIT	EAB0	R	2	Linear	Sets Input Under voltage warning threshold(86V)
59h	VIN_UV_FAULT_LIMIT	EA78	R	2	Linear	Sets Input Under voltage threshold(79V)
5Ah	VIN_UV_FAULT_RESPONSE	F8	R	1	Linear	Turn PSU OFF
5Eh	POWER_GOOD_ON	2E00	R	2	Linear	Sets the threshold by which the Power Good signal is asserted. (19V)
5Fh	POWER_GOOD_OFF	2B33	R	2	Linear	Sets the threshold by which the Power Good signal is de-asserted.
60h	TON_DELAY	EB20	R	2	Linear	Sets the time (sec), from start condition (Power ON) until the output starts to rise. 100mS
61h	TON_RISE	DA80	R	2	Linear	Sets the time (ms), for the output rises from 0 to regulation. 20mS
64h	TOFF_DELAY	DA80	R	2	Linear	Sets the time (ms), from a stop condition (Power OFF) until the output starts to drop (converter OFF).
78h	STATUS_BYTE	00	R	1	Binary	Returns the summary of critical faults
	b7 – BUSY					A fault was declared because the device was busy and unable to respond.
	b6 – OFF					Unit is OFF
	b5 – VOUT_OV					Output over-voltage fault has occurred
	b4 – IOUT_OC					Output over-current fault has occurred
	b3 - VIN_UV					An input under--voltage fault has occurred
	b2 - TEMPERATURE					A temperature fault or warning has occurred
	b1 – CML					A communication, memory or logic fault has occurred.
	b0 – NONE OF THE ABOVE					A Fault Warning not listed in bits[7:1] has occurred.

PMBUS™ SPECIFICATIONS

The LCM1500Q Series Supported PMBus™ Command List:

Command Code	Command Name	Default Value	Access Type	Data Bytes	Data Format	Description
79h	STATUS_WORD	0000	R	2	Binary	Summary of units Fault and warning status.
	b15 – VOUT					An output voltage fault or warning has occurred
	b14 – IOUT/POUT					An Output current or power fault or warning has occurred.
	b13 – INPUT					An input voltage, current or power fault or warning as occurred.
	b12 – MFR					A manufacturer specific fault or warning has occurred.
	b11 – POWER_GOOD#					The POWER_GOOD signal is de-asserted
	b10 - FANS					A fan or airflow fault or warning has occurred.
	b9 – OTHER					A bit in STATUS_OTHER is set.
	b8 – UNKNOWN					A fault type not given in bits [15:1] of the STATUS_WORD has been detected.
	b7 – BUSY					A fault was declared because the device was busy and unable to respond.
	b6 – OFF					Unit is OFF
	b5 – VOUT_OV					Output over-voltage fault has occurred
	b4 – IOUT_OC					Output over-current fault has occurred
	b3 - VIN_UV					An input under-voltage fault has occurred
	b2 – TEMPERATURE					A temperature fault or warning has occurred
	b1 – CML					A communication, memory or logic fault has occurred.
b0 – NONE_OF_THE_ABOVE					A fault or warning not listed in bits[7:1] of this byte has occurred.	
7Ah	STATUS_VOUT	00	R	1	Binary	Output voltage related faults and warnings
	b7					VOUT Over--voltage Fault
	b6					VOUT Over-voltage warning
	b5					VOUT Under-voltage Warning
	b4					VOUT Under-voltage Fault
	b3					VOUT_MAX Warning, an attempt has been made to set output to a value higher that the highest permissible voltage.
	b2					TON_MAX_FAULT
	b1					TOFF_MAX Warning
	b0					reserved

PMBUS™ SPECIFICATIONS

The LCM1500Q Series Supported PMBus™ Command List:

Command Code	Command Name	Default Value	Access Type	Data Bytes	Data Format	Description
7Bh	STATUS_IOUT	00	R	1	Binary	Output Current related faults and warnings
	b7					IOUT Over current Fault
	b6					IOUT Over current And Low Voltage shutdown Fault
	b5					VOUT Under-voltage Warning
	b4					VOUT Under-voltage Fault
	b3					VOUT_MAX Warning, an attempt has been made to set output to a value higher than the highest permissible voltage.
	b2					TON_MAX_FAULT
	b1					TOFF_MAX Warning
b0					reserved	
7Dh	STATUS_TEMPERATURE	00	R	1	Binary	Temperature related faults and warnings
	b7					Over temperature Fault
	b6					Over temperature Warning
	b5					Under temperature Warning
	b4					Under temperature Fault
	b3:0					reserved
7Eh	STATUS_CML	C0	R	1	Binary	Communications, Logic and Memory
80h	STATUS_MFR_SPECIFIC	0	R	1	Binary	Manufacturer Status codes
88h	READ_VIN	-	R	2	Linear	Returns input Voltage in Volts ac
8Bh	READ_VOUT	-	R	2	Linear	Returns the actual, measured voltage in Volts.
8Ch	READ_IOUT	-	R	2	Linear	Returns the output current in amperes.
8Dh	READ_TEMPERATURE_1	-	R	2	Linear	PSU Air inlet temp (inside PSU)
8Eh	READ_TEMPERATURE_2	-	R	2	Linear	PSU Air inlet temp (inside PSU)
96h	READ_POUT	-	R	2	Linear	Returns the output power, in Watts.
97h	READ_PIN	-	R	2	Linear	Returns the input power, in Watts
99h	MFR_ID	-	R/W	8	ASCII	Artesyn
9Ah	MFR_MODEL	-	R/W	8	ASCII	LCM1500
9Bh	MFR_REVISION	-	R/W	2	ASCII	
9Ch	MFR_LOCATION	-	R/W	8	ASCII	Laguna
9Dh	MFR_DATE	-	R/W	8	ASCII	Manufacture Date, ASCII format structure : YYMMDD
9Eh	MFR_SERIAL	-	R/W	13	ASCII	13 CHAR

PMBUS™ SPECIFICATIONS

The LCM1500Q Series Supported PMBus™ Command List:

Command Code	Command Name	Default Value	Access Type	Data Bytes	Data Format	Description
A0h	MFR_VIN_MIN	EAD0	R	2	Linear	Minimum Input Voltage (90Vac)
A1h	MFR_VIN_MAX	FA10	R	2	Linear	Maximum Input Voltage (264Vac)
A2h	MFR_IIN_MAX	DA60	R	2	Linear	Maximum Input Current (19A)
A4h	MFR_VOUT_MIN	2B33	R	2	Linear	Minimum Output Voltage Regulation Window. (21.6V)
A5h	MFR_VOUT_MAX	34CC	R	2	Linear	Maximum Output Voltage. Regulation Window
A6h	MFR_IOOUT_MAX	EA08	R	2	Linear	Maximum Output Current
A7h	MFR_POOUT_MAX	0B0C	R	2	Linear	Maximum Output Power (1560W)
A8h	MFR_TAMBIENT_MAX	EA30	R	2	Linear	Maximum Operating Ambient Temperature (Secondary Ambient) (70 degC)
A9h	MFR_TAMBIENT_MIN	-	R	2	Linear	Minimum Operating Ambient Temperature (Secondary Ambient) (0 degC)
E0h	FW_PRI_VERSION	-	BR	8	ASCII	Varies
E1h	FW_SEC_VERSION	-	BR	8	ASCII	Varies

PMBUS™ SPECIFICATIONS

The LCM1500N Series Supported PMBus™ Command List:

Command Code	Command Name	Default Value	Access Type	Data Bytes	Data Format	Description
01h	OPERATION	80	R/W	1	B	Used to turn the unit ON/OFF in conjunction with the input INH_EN pin.
02h	ON_OFF_CONFIG	1E	R	1	B	Configures the combination of INH_EN pin and serial communication commands needed to turn the unit ON/OFF.
03h	CLEAR_FAULTS	-	S	1		
10h	WRITE_PROTECT	80	R/W	1	MSF	Used to Control Writing to the PMBus Device 80h - Disables write except 10h 40h - Disables write except 10h, 01h, 00h 20h - Disables write except 10h,01h,00h,02h and 21h commands 00 - Enables write to all writeable commands.
15h	STORE_USER_ALL	-	S	0		Copies the Operating memory table to the matching USER non-volatile memory.
21h	VOUT_COMMAND	1E00	R/W	2	Linear	Output Voltage Reference Vout command sends discreet value to change or trim output voltage. (15V)
24h	VOUT_MAX	2100	R	2	Linear	Sets the max adjustable output voltage limit. (16.5V)
3Ah	FAN_CONFIG_1_2	99h	R	1	Bitmapped	Read only to reflect setting of Fans
3Bh	FAN_COMMAND_1	0	R/W	2	Linear	Adjust fan speed, duty cycle control from 0 to 100%
3Ch	FAN_COMMAND_2	0	R/W	2	Linear	Adjust fan speed, duty cycle control from 0 to 100%
40h	VOUT_OV_FAULT_LIMIT	2700	R/W	2	Linear	Sets Output Over-voltage threshold. (19.5V)
41h	VOUT_OV_FAULT_RESPONSE	80	R	1	MSF	Unit Latches OFF. Resets on INH_EN or CONTROL pin recycle or AC recycle.
42h	VOUT_OV_WARN_LIMIT	2360	R	2	Linear	Over-voltage Warning threshold. (17.7V)
43h	VOUT_UV_WARN_LIMIT	1800	R	2	Linear	Under-voltage Warning threshold. (12V)
44h	VOUT_UV_FAULT_LIMIT	1799	R	2	Linear	Under-voltage Fault threshold. (11.8V)
45h	VOUT_UV_FAULT_RESPONSE	80	R	1	MSF	Turn PSU OFF
46h	IOUT_OC_FAULT_LIMIT	EB60	R	2	Linear	Over current threshold in Amps. (108A)
47h	IOUT_OC_FAULT_RESPONSE	C0	R	1	MSF	OCP ride through. If OCP persists.
4Ah	IOUT_OC_WARN_LIMIT	EB30	R	2	Linear	Over Current Warning threshold in Amps. (102A)
4Fh	OT_FAULT_LIMIT	EBB0	R	2	Linear	Secondary ambient temperature Fault threshold, in degree C. (118degC)

PMBUS™ SPECIFICATIONS

The LCM1500N Series Supported PMBus™ Command List:

Command Code	Command Name	Default Value	Access Type	Data Bytes	Data Format	Description
50h	OT_FAULT_RESPONSE	F8	R	1	MSF	Turn PSU OFF and will retry indefinitely
51h	OT_WARN_LIMIT	EA30	R	2	Linear	Secondary ambient temperature warning threshold, in degree C.(114degC)
55h	VIN_OV_FAULT_LIMIT	FA3A	R	2	Linear	Sets Input Over voltage threshold. (285V)
56h	VIN_OV_FAULT_RESPONSE	C0	R	1	Linear	Turn PSU OFF
58h	VIN_UV_WARN_LIMIT	EAB0	R	2	Linear	Sets Input Under voltage warning threshold(86V)
59h	VIN_UV_FAULT_LIMIT	EA78	R	2	Linear	Sets Input Under voltage threshold(79V)
5Ah	VIN_UV_FAULT_RESPONSE	F8	R	1	Linear	Turn PSU OFF
5Eh	POWER_GOOD_ON	1957	R	2	Linear	Sets the threshold by which the Power Good signal is asserted. (12.67V)
5Fh	POWER_GOOD_OFF	1900	R	2	Linear	Sets the threshold by which the Power Good signal is de-asserted. (12.5V)
60h	TON_DELAY	EB20	R	2	Linear	Sets the time (sec), from start condition (Power ON) until the output starts to rise. 100mS
61h	TON_RISE	DA80	R	2	Linear	Sets the time (ms), for the output rises from 0 to regulation. 20mS
64h	TOFF_DELAY	DA80	R	2	Linear	Sets the time (ms), from a stop condition (Power OFF) until the output starts to drop (converter OFF).
78h	STATUS_BYTE	00	R	1	Binary	Returns the summary of critical faults
	b7 – BUSY					A fault was declared because the device was busy and unable to respond.
	b6 – OFF					Unit is OFF
	b5 – VOUT_OV					Output over-voltage fault has occurred
	b4 – IOUT_OC					Output over-current fault has occurred
	b3 - VIN_UV					An input under--voltage fault has occurred
	b2 - TEMPERATURE					A temperature fault or warning has occurred
	b1 – CML					A communication, memory or logic fault has occurred.
	b0 – NONE OF THE ABOVE					A Fault Warning not listed in bits[7:1] has occurred.

PMBUS™ SPECIFICATIONS

The LCM1500N Series Supported PMBus™ Command List:

Command Code	Command Name	Default Value	Access Type	Data Bytes	Data Format	Description
79h	STATUS_WORD	0000	R	2	Binary	Summary of units Fault and warning status.
	b15 – VOUT					An output voltage fault or warning has occurred
	b14 – IOUT/POUT					An Output current or power fault or warning has occurred.
	b13 – INPUT					An input voltage, current or power fault or warning as occurred.
	b12 – MFR					A manufacturer specific fault or warning has occurred.
	b11 – POWER_GOOD#					The POWER_GOOD signal is de-asserted
	b10 - FANS					A fan or airflow fault or warning has occurred.
	b9 – OTHER					A bit in STATUS_OTHER is set.
	b8 – UNKNOWN					A fault type not given in bits [15:1] of the STATUS_WORD has been detected.
	b7 – BUSY					A fault was declared because the device was busy and unable to respond.
	b6 – OFF					Unit is OFF
	b5 – VOUT_OV					Output over-voltage fault has occurred
	b4 – IOUT_OC					Output over-current fault has occurred
	b3 - VIN_UV					An input under-voltage fault has occurred
	b2 – TEMPERATURE					A temperature fault or warning has occurred
	b1 – CML					A communication, memory or logic fault has occurred.
b0 – NONE_OF_THE_ABOVE					A fault or warning not listed in bits[7:1] of this byte has occurred.	
7Ah	STATUS_VOUT	00	R	1	Binary	Output voltage related faults and warnings
	b7					VOUT Over--voltage Fault
	b6					VOUT Over-voltage warning
	b5					VOUT Under-voltage Warning
	b4					VOUT Under-voltage Fault
	b3					VOUT_MAX Warning, an attempt has been made to set output to a value higher that the highest permissible voltage.
	b2					TON_MAX_FAULT
	b1					TOFF_MAX Warning
	b0					reserved

PMBUS™ SPECIFICATIONS

The LCM1500N Series Supported PMBus™ Command List:

Command Code	Command Name	Default Value	Access Type	Data Bytes	Data Format	Description
7Bh	STATUS_IOUT	00	R	1	Binary	Output Current related faults and warnings
	b7					IOUT Over current Fault
	b6					IOUT Over current And Low Voltage shutdown Fault
	b5					VOUT Under-voltage Warning
	b4					VOUT Under-voltage Fault
	b3					VOUT_MAX Warning, an attempt has been made to set output to a value higher than the highest permissible voltage.
	b2					TON_MAX_FAULT
	b1					TOFF_MAX Warning
	b0					reserved
7Dh	STATUS_TEMPERATURE	00	R	1	Binary	Temperature related faults and warnings
	b7					Over temperature Fault
	b6					Over temperature Warning
	b5					Under temperature Warning
	b4					Under temperature Fault
	b3:0					reserved
7Eh	STATUS_CML	C0	R	1	Binary	Communications, Logic and Memory
80h	STATUS_MFR_SPECIFIC	0	R	1	Binary	Manufacturer Status codes
88h	READ_VIN	-	R	2	Linear	Returns input Voltage in Volts ac
8Bh	READ_VOUT	-	R	2	Linear	Returns the actual, measured voltage in Volts.
8Ch	READ_IOUT	-	R	2	Linear	Returns the output current in amperes.
8Dh	READ_TEMPERATURE_1	-	R	2	Linear	PSU Air inlet temp (inside PSU)
8Eh	READ_TEMPERATURE_2	-	R	2	Linear	PSU Air inlet temp (inside PSU)
96h	READ_POUT	-	R	2	Linear	Returns the output power, in Watts.
97h	READ_PIN	-	R	2	Linear	Returns the input power, in Watts
99h	MFR_ID	-	R/W	8	ASCII	Artesyn
9Ah	MFR_MODEL	-	R/W	8	ASCII	LCM1500
9Bh	MFR_REVISION	-	R/W	2	ASCII	
9Ch	MFR_LOCATION	-	R/W	8	ASCII	Laguna
9Dh	MFR_DATE	-	R/W	8	ASCII	Manufacture Date, ASCII format structure : YYMMDD
9Eh	MFR_SERIAL	-	R/W	13	ASCII	13 CHAR

PMBUS™ SPECIFICATIONS

The LCM1500N Series Supported PMBus™ Command List:

Command Code	Command Name	Default Value	Access Type	Data Bytes	Data Format	Description
A0h	MFR_VIN_MIN	EAD0	R	2	Linear	Minimum Input Voltage (90Vac)
A1h	MFR_VIN_MAX	FA10	R	2	Linear	Maximum Input Voltage (264Vac)
A2h	MFR_IIN_MAX	DA40	R	2	Linear	Maximum Input Current (18A)
A4h	MFR_VOUT_MIN	1B00	R	2	Linear	Minimum Output Voltage Regulation Window. (13.5V)
A5h	MFR_VOUT_MAX	8448	R	2	Linear	Maximum Output Voltage. Regulation Window (16.5V)
A6h	MFR_IOUT_MAX	EB20	R	2	Linear	Maximum Output Current (100A)
A7h	MFR_POUT_MAX	-	R	2	Linear	Maximum Output Power (1560W)
A8h	MFR_TAMBIENT_MAX	EA30	R	2	Linear	Maximum Operating Ambient Temperature (Secondary Ambient) (70 degC)
A9h	MFR_TAMBIENT_MIN	-	R	2	Linear	Minimum Operating Ambient Temperature (Secondary Ambient) (-40 degC)
E0h	FW_PRI_VERSION	-	BR	8	ASCII	Varies
E1h	FW_SEC_VERSION	-	BR	8	ASCII	Varies

PMBUS™ SPECIFICATIONS

The LCM1500R Series Supported PMBus™ Command List:

Command Code	Command Name	Default Value	Access Type	Data Bytes	Data Format	Description
01h	OPERATION	80	R/W	1	B	Used to turn the unit ON/OFF in conjunction with the input INH_EN pin.
02h	ON_OFF_CONFIG	1E	R	1	B	Configures the combination of INH_EN pin and serial communication commands needed to turn the unit ON/OFF.
03h	CLEAR_FAULTS	-	S	1		
10h	WRITE_PROTECT	80	R/W	1	MSF	Used to Control Writing to the PMBus Device 80h - Disables write except 10h 40h - Disables write except 10h, 01h, 00h 20h - Disables write except 10h,01h,00h,02h and 21h commands 00 -Enables write to all writeable commands.
15h	STORE_USER_ALL	-	S	0		Copies the Operating memory table to the matching USER non-volatile memory.
20h	VOUT_MODE	17	R	1	B	Specifies the mode and parameters of Output Voltage related Data Formats
21h	VOUT_COMMAND	3800	R/W	2	Linear	Sets the Output Voltage Reference Vout command sends discreet value to change or trim output voltage. (28V)
24h	VOUT_MAX	3D99	R	2	Linear	The max adjustable output voltage limit. (30.8V)
3Ah	FAN_CONFIG_1_2	99h	R	1	Bitmapped	Read only to reflect setting of Fans
3Bh	FAN_COMMAND_1	0	R/W	2	Linear	Adjust fan speed, duty cycle control from 0 to 100%
3Ch	FAN_COMMAND_2	0	R/W	2	Linear	Adjust fan speed, duty cycle control from 0 to 100%
40h	VOUT_OV_FAULT_LIMIT	-	R/W	2	Linear	Sets Output Over voltage threshold. (48.6V)
41h	VOUT_OV_FAULT_RESPONSE	80	R	1	MSF	Unit Latches OFF. Resets on INH_EN or CONTROL pin recycle or AC recycle.
42h	VOUT_OV_WARN_LIMIT	-	R	2	Linear	Over-voltage Warning threshold. (42.5V)
43h	VOUT_UV_WARN_LIMIT	-	R	2	Linear	Under-voltage Warning threshold. (30.6V)
44h	VOUT_UV_FAULT_LIMIT	-	R	2	Linear	Under-voltage Fault threshold. (30V)
45h	VOUT_UV_FAULT_RESPONSE	80	R	1	MSF	Turn PSU OFF
46h	IOUT_OC_FAULT_LIMIT	E2D0	R	2	Linear	Over current threshold in Amps. (45A)
47h	IOUT_OC_FAULT_RESPONSE	C0	R	1	MSF	OCP ride through. If OCP persists.
4Ah	IOUT_OC_WARN_LIMIT	E2A8	R	2	Linear	Over Current Warning threshold in Amps. (42.5A)

PMBUS™ SPECIFICATIONS

The LCM1500R Series Supported PMBus™ Command List:

Command Code	Command Name	Default Value	Access Type	Data Bytes	Data Format	Description
4Fh	OT_FAULT_LIMIT	EBB0	R	2	Linear	Secondary ambient temperature Fault threshold, in degree C. (118degC)
50h	OT_FAULT_RESPONSE	-	R	1	MSF	Turn PSU OFF and will retry indefinitely
51h	OT_WARN_LIMIT	EA30	R	2	Linear	Secondary ambient temperature warning threshold, in degree C.(70degC)
55h	VIN_OV_FAULT_LIMIT	FA3A	R	2	Linear	Sets Input Over voltage threshold. (285V)
56h	VIN_OV_FAULT_RESPONSE	C0	R	1	Linear	Turn PSU OFF
58h	VIN_UV_WARN_LIMIT	EAB0	R	2	Linear	Sets Input Under voltage warning threshold(86V)
59h	VIN_UV_FAULT_LIMIT	EA78	R	2	Linear	Sets Input Under voltage threshold(79V)
5Ah	VIN_UV_FAULT_RESPONSE	F8	R	1	Linear	Turn PSU OFF
5Eh	POWER_GOOD_ON	-	R	2	Linear	Sets the threshold by which the Power Good signal is asserted. (32.25V)
5Fh	POWER_GOOD_OFF	-	R	2	Linear	Sets the threshold by which the Power Good signal is de-asserted. (31.86V)
60h	TON_DELAY	EB20	R	2	Linear	Sets the time (sec), from start condition (Power ON) until the output starts to rise. 100mS
61h	TON_RISE	DA80	R	2	Linear	Sets the time (ms), for the output rises from 0 to regulation. 20mS
64h	TOFF_DELAY	DA80	R	2	Linear	Sets the time (ms), from a stop condition (Power OFF) until the output starts to drop (converter OFF).
78h	STATUS_BYTE	00	R	1	Binary	Returns the summary of critical faults
	b7 – BUSY					A fault was declared because the device was busy and unable to respond.
	b6 – OFF					Unit is OFF
	b5 – VOUT_OV					Output over-voltage fault has occurred
	b4 – IOUT_OC					Output over-current fault has occurred
	b3 – VIN_UV					An input under-voltage fault has occurred
	b2 – TEMPERATURE					A temperature fault or warning has occurred
	b1 – CML					A communication, memory or logic fault has occurred.
	b0 – NONE OF THE ABOVE					A Fault Warning not listed in bits[7:1] has occurred.

PMBUS™ SPECIFICATIONS

The LCM1500R Series Supported PMBus™ Command List:

Command Code	Command Name	Default Value	Access Type	Data Bytes	Data Format	Description
79h	STATUS_WORD	0000	R	2	Binary	Summary of units Fault and warning status.
	b15 – VOUT					An output voltage fault or warning has occurred
	b14 – IOUT/POUT					An Output current or power fault or warning has occurred.
	b13 – INPUT					An input voltage, current or power fault or warning as occurred.
	b12 – MFR					A manufacturer specific fault or warning has occurred.
	b11 – POWER_GOOD#					The POWER_GOOD signal is de-asserted
	b10 - FANS					A fan or airflow fault or warning has occurred.
	b9 – OTHER					A bit in STATUS_OTHER is set.
	b8 – UNKNOWN					A fault type not given in bits [15:1] of the STATUS_WORD has been detected.
	b7 – BUSY					A fault was declared because the device was busy and unable to respond.
	b6 – OFF					Unit is OFF
	b5 – VOUT_OV					Output over-voltage fault has occurred
	b4 – IOUT_OC					Output over-current fault has occurred
	b3 - VIN_UV					An input under-voltage fault has occurred
	b2 – TEMPERATURE					A temperature fault or warning has occurred
	b1 – CML					A communication, memory or logic fault has occurred.
b0 – NONE_OF_THE_ABOVE					A fault or warning not listed in bits[7:1] of this byte has occurred.	
7Ah	STATUS_VOUT	00	R	1	Binary	Output voltage related faults and warnings
	b7					VOUT Over--voltage Fault
	b6					VOUT Over-voltage warning
	b5					VOUT Under-voltage Warning
	b4					VOUT Under-voltage Fault
	b3					VOUT_MAX Warning, an attempt has been made to set output to a value higher than the highest permissible voltage.
	b2					TON_MAX_FAULT
	b1					TOFF_MAX Warning
	b0					reserved

PMBUS™ SPECIFICATIONS

The LCM1500R Series Supported PMBus™ Command List:

Command Code	Command Name	Default Value	Access Type	Data Bytes	Data Format	Description
7Bh	STATUS_IOUT	00	R	1	Binary	Output Current related faults and warnings
	b7					IOUT Over current Fault
	b6					IOUT Over current And Low Voltage shutdown Fault
	b5					VOUT Under-voltage Warning
	b4					VOUT Under-voltage Fault
	b3					VOUT_MAX Warning, an attempt has been made to set output to a value higher than the highest permissible voltage.
	b2					TON_MAX_FAULT
	b1					TOFF_MAX Warning
b0					reserved	
7Dh	STATUS_TEMPERATURE	00	R	1	Binary	Temperature related faults and warnings
	b7					Over temperature Fault
	b6					Over temperature Warning
	b5					Under temperature Warning
	b4					Under temperature Fault
	b3:0					reserved
7Eh	STATUS_CML	C0	R	1	Binary	Communications, Logic and Memory
80h	STATUS_MFR_SPECIFIC	0	R	1	Binary	Manufacturer Status codes
88h	READ_VIN	-	R	2	Linear	Returns input Voltage in Volts ac
8Bh	READ_VOUT	-	R	2	Linear	Returns the actual, measured voltage in Volts.
8Ch	READ_IOUT	-	R	2	Linear	Returns the output current in amperes.
8Dh	READ_TEMPERATURE_1	-	R	2	Linear	PSU Air inlet temp (inside PSU)
8Eh	READ_TEMPERATURE_2	-	R	2	Linear	PSU Air inlet temp (inside PSU)
96h	READ_POUT	-	R	2	Linear	Returns the output power, in Watts.
97h	READ_PIN	-	R	2	Linear	Returns the input power, in Watts
99h	MFR_ID	-	R/W	8	ASCII	Artesyn
9Ah	MFR_MODEL	-	R/W	8	ASCII	LCM1500
9Bh	MFR_REVISION	-	R/W	2	ASCII	
9Ch	MFR_LOCATION	-	R/W	8	ASCII	Laguna
9Dh	MFR_DATE	-	R/W	8	ASCII	Manufacture Date, ASCII format structure : YYYYMMDD
9Eh	MFR_SERIAL	-	R/W	13	ASCII	13 CHAR

PMBUS™ SPECIFICATIONS

The LCM1500R Series Supported PMBus™ Command List:

Command Code	Command Name	Default Value	Access Type	Data Bytes	Data Format	Description
A0h	MFR_VIN_MIN	EAD0	R	2	Linear	Minimum Input Voltage (90Vac)
A1h	MFR_VIN_MAX	FA10	R	2	Linear	Maximum Input Voltage (264Vac)
A2h	MFR_IIN_MAX	DA40	R	2	Linear	Maximum Input Current (18A)
A4h	MFR_VOUT_MIN	1B00	R	2	Linear	Minimum Output Voltage Regulation Window. (13.5V)
A5h	MFR_VOUT_MAX	8448	R	2	Linear	Maximum Output Voltage. Regulation Window (16.5V)
A6h	MFR_IOUT_MAX	EB20	R	2	Linear	Maximum Output Current (100A)
A7h	MFR_POUT_MAX	-	R	2	Linear	Maximum Output Power (1560W)
A8h	MFR_TAMBIENT_MAX	EA30	R	2	Linear	Maximum Operating Ambient Temperature (Secondary Ambient) (70 degC)
A9h	MFR_TAMBIENT_MIN	-	R	2	Linear	Minimum Operating Ambient Temperature (Secondary Ambient) (-40 degC)
E0h	FW_PRI_VERSION	-	BR	8	ASCII	Varies
E1h	FW_SEC_VERSION	-	BR	8	ASCII	Varies

PMBUS™ SPECIFICATIONS

The LCM1500U Series Supported PMBus™ Command List:

Command Code	Command Name	Default Value	Access Type	Data Bytes	Data Format	Description
01h	OPERATION	80	R/W	1	B	Used to turn the unit ON/OFF in conjunction with the input INH_EN pin.
02h	ON_OFF_CONFIG	1E	R	1	B	Configures the combination of INH_EN pin and serial communication commands needed to turn the unit ON/OFF.
03h	CLEAR_FAULTS	-	S	1		
10h	WRITE_PROTECT	80	R/W	1	MSF	Used to Control Writing to the PMBus Device 80h - Disables write except 10h 40h - Disables write except 10h, 01h, 00h 20h - Disables write except 10h,01h,00h,02h and 21h commands 00 -Enables write to all writeable commands.
15h	STORE_USER_ALL	-	S	0		Copies the Operating memory table to the matching USER non-volatile memory.
20h	VOUT_MODE	17	R	1	B	Specifies the mode and parameters of Output Voltage related Data Formats
21h	VOUT_COMMAND	4800	R/W	2	Linear	Sets the Output Voltage Reference Vout command sends discreet value to change or trim output voltage. (36V)
24h	VOUT_MAX	4F33	R	2	Linear	The max adjustable output voltage limit. (39.6V)
3Ah	FAN_CONFIG_1_2	99h	R	1	Bitmapped	Read only to reflect setting of Fans
3Bh	FAN_COMMAND_1	0	R/W	2	Linear	Adjust fan speed, duty cycle control from 0 to 100%
3Ch	FAN_COMMAND_2	0	R/W	2	Linear	Adjust fan speed, duty cycle control from 0 to 100%
40h	VOUT_OV_FAULT_LIMIT	6133	R/W	2	Linear	Sets Output Over voltage threshold. (48.6V)
41h	VOUT_OV_FAULT_RESPONSE	80	R	1	MSF	Unit Latches OFF. Resets on INH_EN or CONTROL pin recycle or AC recycle.
42h	VOUT_OV_WARN_LIMIT	5500	R	2	Linear	Over-voltage Warning threshold. (42.5V)
43h	VOUT_UV_WARN_LIMIT	3D33	R	2	Linear	Under-voltage Warning threshold. (30.6V)
44h	VOUT_UV_FAULT_LIMIT	3C00	R	2	Linear	Under-voltage Fault threshold. (30V)
45h	VOUT_UV_FAULT_RESPONSE	80	R	1	MSF	Turn PSU OFF
46h	IOUT_OC_FAULT_LIMIT	E2D0	R	2	Linear	Over current threshold in Amps. (45A)
47h	IOUT_OC_FAULT_RESPONSE	C0	R	1	MSF	OCP ride through. If OCP persists.
4Ah	IOUT_OC_WARN_LIMIT	E2A8	R	2	Linear	Over Current Warning threshold in Amps. (42.5A)

PMBUS™ SPECIFICATIONS

The LCM1500U Series Supported PMBus™ Command List:

Command Code	Command Name	Default Value	Access Type	Data Bytes	Data Format	Description
4Fh	OT_FAULT_LIMIT	EBB0	R	2	Linear	Secondary ambient temperature Fault threshold, in degree C. (118degC)
50h	OT_FAULT_RESPONSE	F8	R	1	MSF	Turn PSU OFF and will retry indefinitely
51h	OT_WARN_LIMIT	EA30	R	2	Linear	Secondary ambient temperature warning threshold, in degree C.(70degC)
55h	VIN_OV_FAULT_LIMIT	FA3A	R	2	Linear	Sets Input Over voltage threshold. (285V)
56h	VIN_OV_FAULT_RESPONSE	C0	R	1	Linear	Turn PSU OFF
58h	VIN_UV_WARN_LIMIT	EAB0	R	2	Linear	Sets Input Under voltage warning threshold(86V)
59h	VIN_UV_FAULT_LIMIT	EA78	R	2	Linear	Sets Input Under voltage threshold(79V)
5Ah	VIN_UV_FAULT_RESPONSE	F8	R	1	Linear	Turn PSU OFF
5Eh	POWER_GOOD_ON	4100	R	2	Linear	Sets the threshold by which the Power Good signal is asserted. (32.5V)
5Fh	POWER_GOOD_OFF	3FB8	R	2	Linear	Sets the threshold by which the Power Good signal is de-asserted. (31.86V)
60h	TON_DELAY	EB20	R	2	Linear	Sets the time (sec), from start condition (Power ON) until the output starts to rise. 100mS
61h	TON_RISE	DA80	R	2	Linear	Sets the time (ms), for the output rises from 0 to regulation. 20mS
64h	TOFF_DELAY	DA80	R	2	Linear	Sets the time (ms), from a stop condition (Power OFF) until the output starts to drop (converter OFF).
78h	STATUS_BYTE	00	R	1	Binary	Returns the summary of critical faults
	b7 – BUSY					A fault was declared because the device was busy and unable to respond.
	b6 – OFF					Unit is OFF
	b5 – VOUT_OV					Output over-voltage fault has occurred
	b4 – IOUT_OC					Output over-current fault has occurred
	b3 - VIN_UV					An input under-voltage fault has occurred
	b2 - TEMPERATURE					A temperature fault or warning has occurred
	b1 – CML					A communication, memory or logic fault has occurred.
	b0 – NONE OF THE ABOVE					A Fault Warning not listed in bits[7:1] has occurred.

PMBUS™ SPECIFICATIONS

The LCM1500U Series Supported PMBus™ Command List:

Command Code	Command Name	Default Value	Access Type	Data Bytes	Data Format	Description
79h	STATUS_WORD	0000	R	2	Binary	Summary of units Fault and warning status.
	b15 – VOUT					An output voltage fault or warning has occurred
	b14 – IOUT/POUT					An Output current or power fault or warning has occurred.
	b13 – INPUT					An input voltage, current or power fault or warning as occurred.
	b12 – MFR					A manufacturer specific fault or warning has occurred.
	b11 – POWER_GOOD#					The POWER_GOOD signal is de-asserted
	b10 - FANS					A fan or airflow fault or warning has occurred.
	b9 – OTHER					A bit in STATUS_OTHER is set.
	b8 – UNKNOWN					A fault type not given in bits [15:1] of the STATUS_WORD has been detected.
	b7 – BUSY					A fault was declared because the device was busy and unable to respond.
	b6 – OFF					Unit is OFF
	b5 – VOUT_OV					Output over-voltage fault has occurred
	b4 – IOUT_OC					Output over-current fault has occurred
	b3 - VIN_UV					An input under-voltage fault has occurred
	b2 – TEMPERATURE					A temperature fault or warning has occurred
	b1 – CML					A communication, memory or logic fault has occurred.
b0 – NONE_OF_THE_ABOVE					A fault or warning not listed in bits[7:1] of this byte has occurred.	
7Ah	STATUS_VOUT	00	R	1	Binary	Output voltage related faults and warnings
	b7					VOUT Over--voltage Fault
	b6					VOUT Over-voltage warning
	b5					VOUT Under-voltage Warning
	b4					VOUT Under-voltage Fault
	b3					VOUT_MAX Warning, an attempt has been made to set output to a value higher that the highest permissible voltage.
	b2					TON_MAX_FAULT
	b1					TOFF_MAX Warning
	b0					reserved

PMBUS™ SPECIFICATIONS

The LCM1500U Series Supported PMBus™ Command List:

Command Code	Command Name	Default Value	Access Type	Data Bytes	Data Format	Description
7Bh	STATUS_IOUT	00	R	1	Binary	Output Current related faults and warnings
	b7					IOUT Over current Fault
	b6					IOUT Over current And Low Voltage shutdown Fault
	b5					VOUT Under-voltage Warning
	b4					VOUT Under-voltage Fault
	b3					VOUT_MAX Warning, an attempt has been made to set output to a value higher than the highest permissible voltage.
	b2					TON_MAX_FAULT
	b1					TOFF_MAX Warning
	b0					reserved
7Dh	STATUS_TEMPERATURE	00	R	1	Binary	Temperature related faults and warnings
	b7					Overtemperature Fault
	b6					Overtemperature Warning
	b5					Under temperature Warning
	b4					Under temperature Fault
	b3:0					reserved
7Eh	STATUS_CML	C0	R	1	Binary	Communications, Logic and Memory
80h	STATUS_MFR_SPECIFIC	0	R	1	Binary	Manufacturer Status codes
88h	READ_VIN	-	R	2	Linear	Returns input Voltage in Volts ac
8Bh	READ_VOUT	-	R	2	Linear	Returns the actual, measured voltage in Volts.
8Ch	READ_IOUT	-	R	2	Linear	Returns the output current in amperes.
8Dh	READ_TEMPERATURE_1	-	R	2	Linear	PSU Air inlet temp (inside PSU)
8Eh	READ_TEMPERATURE_2	-	R	2	Linear	PSU Air inlet temp (inside PSU)
96h	READ_POUT	-	R	2	Linear	Returns the output power, in Watts.
97h	READ_PIN	-	R	2	Linear	Returns the input power, in Watts
99h	MFR_ID	-	R/W	8	ASCII	Artesyn
9Ah	MFR_MODEL	-	R/W	8	ASCII	LCM1500
9Bh	MFR_REVISION	-	R/W	2	ASCII	
9Ch	MFR_LOCATION	-	R/W	8	ASCII	Laguna
9Dh	MFR_DATE	-	R/W	8	ASCII	Manufacture Date, ASCII format structure : YYMMDD
9Eh	MFR_SERIAL	-	R/W	13	ASCII	13 CHAR

PMBUS™ SPECIFICATIONS

The LCM1500U Series Supported PMBus™ Command List:

Command Code	Command Name	Default Value	Access Type	Data Bytes	Data Format	Description
A0h	MFR_VIN_MIN	EAD0	R	2	Linear	Minimum Input Voltage (90Vac)
A1h	MFR_VIN_MAX	FA10	R	2	Linear	Maximum Input Voltage (264Vac)
A2h	MFR_IIN_MAX	DA40	R	2	Linear	Maximum Input Current (18A)
A4h	MFR_VOUT_MIN	1B00	R	2	Linear	Minimum Output Voltage Regulation Window. (13.5V)
A5h	MFR_VOUT_MAX	8448	R	2	Linear	Maximum Output Voltage. Regulation Window (16.5V)
A6h	MFR_IOUT_MAX	EB20	R	2	Linear	Maximum Output Current (100A)
A7h	MFR_POUT_MAX	-	R	2	Linear	Maximum Output Power (1560W)
A8h	MFR_TAMBIENT_MAX	EA30	R	2	Linear	Maximum Operating Ambient Temperature (Secondary Ambient) (70 degC)
A9h	MFR_TAMBIENT_MIN	-	R	2	Linear	Minimum Operating Ambient Temperature (Secondary Ambient) (-40 degC)
E0h	FW_PRI_VERSION	-	BR	8	ASCII	Varies
E1h	FW_SEC_VERSION	-	BR	8	ASCII	Varies

PMBUS™ SPECIFICATIONS

The LCM1500W Series Supported PMBus™ Command List:

Command Code	Command Name	Default Value	Access Type	Data Bytes	Data Format	Description
01h	OPERATION	80	R/W	1	B	Used to turn the unit ON/OFF in conjunction with the input INH_EN pin.
02h	ON_OFF_CONFIG	1E	R	1	B	Configures the combination of INH_EN pin and serial communication commands needed to turn the unit ON/OFF.
03h	CLEAR_FAULTS	-	S	1		
10h	WRITE_PROTECT	80	R/W	1	MSF	Used to Control Writing to the PMBus Device 80h - Disables write except 10h 40h - Disables write except 10h, 01h, 00h 20h - Disables write except 10h,01h,00h,02h and 21h commands 00 - Enables write to all writeable commands.
15h	STORE_USER_ALL	-	S	0		Copies the Operating memory table to the matching USER non-volatile memory.
20h	VOUT_MODE	18	R	1	B	Specifies the mode and parameters of Output Voltage related Data Formats
21h	VOUT_COMMAND	3000	R/W	2	Linear	Sets the Output Voltage Reference Vout command sends discreet value to change or trim output voltage. (48V)
24h	VOUT_MAX	34CC	R	2	Linear	The max adjustable output voltage limit. (52.8V)
3Ah	FAN_CONFIG_1_2	99h	R	1	Bitmapped	Read only to reflect setting of Fans
3Bh	FAN_COMMAND_1	0	R/W	2	Linear	Adjust fan speed, duty cycle control from 0 to 100%
3Ch	FAN_COMMAND_2	0	R/W	2	Linear	Adjust fan speed, duty cycle control from 0 to 100%
40h	VOUT_OV_FAULT_LIMIT	819A	R/W	2	Linear	Sets Output Over voltage threshold. (64.8V)
41h	VOUT_OV_FAULT_RESPONSE	80	R	1	MSF	Unit Latches OFF. Resets on INH_EN or CONTROL pin recycle or AC recycle.
42h	VOUT_OV_WARN_LIMIT	6E66	R	2	Linear	Over-voltage Warning threshold. (55.2V)
43h	VOUT_UV_WARN_LIMIT	6800	R	2	Linear	Under-voltage Warning threshold. (38.4V)
44h	VOUT_UV_FAULT_LIMIT	6800	R	2	Linear	Sets Under-voltage Fault threshold. (38.4V)
45h	VOUT_UV_FAULT_RESPONSE	80	R	1	MSF	Turn PSU OFF
46h	IOUT_OC_FAULT_LIMIT	E220	R	2	Linear	Over current threshold in Amps. (34A)
47h	IOUT_OC_FAULT_RESPONSE	C0	R	1	MSF	OCP ride through. If OCP persists.
4Ah	IOUT_OC_WARN_LIMIT	E203	R	2	Linear	Over Current Warning threshold in Amps. (32.2A)

PMBUS™ SPECIFICATIONS

The LCM1500W Series Supported PMBus™ Command List:

Command Code	Command Name	Default Value	Access Type	Data Bytes	Data Format	Description
4Fh	OT_FAULT_LIMIT	EBB0	R	2	Linear	Secondary ambient temperature Fault threshold, in degree C. (118degC)
50h	OT_FAULT_RESPONSE	F8	R	1	MSF	Turn PSU OFF and will retry indefinitely
5Eh	POWER_GOOD_ON	6229	R	2	Linear	Sets the threshold by which the Power Good signal is asserted. (46.08V)
5Fh	POWER_GOOD_OFF	5666	R	2	Linear	Sets the threshold by which the Power Good signal is de-asserted. (43.2V)
60h	TON_DELAY	EB20	R	2	Linear	Sets the time (sec), from start condition (Power ON) until the output starts to rise. 100mS
61h	TON_RISE	DA80	R	2	Linear	Sets the time (ms), for the output rises from 0 to regulation. 20mS
64h	TOFF_DELAY	DA80	R	2	Linear	Sets the time (ms), from a stop condition (Power OFF) until the output starts to drop (converter OFF). 20mS
78h	STATUS_BYTE	00	R	1	Binary	Returns the summary of critical faults
	b7 – BUSY					A fault was declared because the device was busy and unable to respond.
	b6 – OFF					Unit is OFF
	b5 – VOUT_OV					Output over-voltage fault has occurred
	b4 – IOUT_OC					Output over-current fault has occurred
	b3 - VIN_UV					An input under--voltage fault has occurred
	b2 - TEMPERATURE					A temperature fault or warning has occurred
	b1 – CML					A communication, memory or logic fault has occurred.
	b0 – NONE OF THE ABOVE					A Fault Warning not listed in bits[7:1] has occurred.

PMBUS™ SPECIFICATIONS

The LCM1500W Series Supported PMBus™ Command List:

Command Code	Command Name	Default Value	Access Type	Data Bytes	Data Format	Description
79h	STATUS_WORD	0000	R	2	Binary	Summary of units Fault and warning status.
	b15 – VOUT					An output voltage fault or warning has occurred
	b14 – IOUT/POUT					An Output current or power fault or warning has occurred.
	b13 – INPUT					An input voltage, current or power fault or warning as occurred.
	b12 – MFR					A manufacturer specific fault or warning has occurred.
	b11 – POWER_GOOD#					The POWER_GOOD signal is de-asserted
	b10 - FANS					A fan or airflow fault or warning has occurred.
	b9 – OTHER					A bit in STATUS_OTHER is set.
	b8 – UNKNOWN					A fault type not given in bits [15:1] of the STATUS_WORD has been detected.
	b7 – BUSY					A fault was declared because the device was busy and unable to respond.
	b6 – OFF					Unit is OFF
	b5 – VOUT_OV					Output over-voltage fault has occurred
	b4 – IOUT_OC					Output over-current fault has occurred
	b3 - VIN_UV					An input under-voltage fault has occurred
	b2 – TEMPERATURE					A temperature fault or warning has occurred
	b1 – CML					A communication, memory or logic fault has occurred.
b0 – NONE_OF_THE_ABOVE					A fault or warning not listed in bits[7:1] of this byte has occurred.	
7Ah	STATUS_VOUT	00	R	1	Binary	Output voltage related faults and warnings
	b7					VOUT Over--voltage Fault
	b6					VOUT Over-voltage warning
	b5					VOUT Under-voltage Warning
	b4					VOUT Under-voltage Fault
	b3					VOUT_MAX Warning, an attempt has been made to set output to a value higher that the highest permissible voltage.
	b2					TON_MAX_FAULT
	b1					TOFF_MAX Warning
	b0					reserved

PMBUS™ SPECIFICATIONS

The LCM1500W Series Supported PMBus™ Command List:

Command Code	Command Name	Default Value	Access Type	Data Bytes	Data Format	Description
7Bh	STATUS_IOUT	00	R	1	Binary	Output Current related faults and warnings
	b7					IOUT Over current Fault
	b6					IOUT Over current And Low Voltage shutdown Fault
	b5					VOUT Under-voltage Warning
	b4					VOUT Under-voltage Fault
	b3					VOUT_MAX Warning, an attempt has been made to set output to a value higher than the highest permissible voltage.
	b2					TON_MAX_FAULT
	b1					TOFF_MAX Warning
	b0					reserved
7Dh	STATUS_TEMPERATURE	00	R	1	Binary	Temperature related faults and warnings
	b7					Over temperature Fault
	b6					Over temperature Warning
	b5					Under temperature Warning
	b4					Under temperature Fault
	b3:0					reserved
7Eh	STATUS_CML	C0	R	1	Binary	Communications, Logic and Memory
80h	STATUS_MFR_SPECIFIC	0	R	1	Binary	Manufacturer Status codes
88h	READ_VIN	-	R	2	Linear	Returns input Voltage in Volts ac
8Bh	READ_VOUT	-	R	2	Linear	Returns the actual, measured voltage in Volts.
8Ch	READ_IOUT	-	R	2	Linear	Returns the output current in amperes.
8Dh	READ_TEMPERATURE_1	-	R	2	Linear	PSU Air inlet temp (inside PSU)
8Eh	READ_TEMPERATURE_2	-	R	2	Linear	PSU Air inlet temp (inside PSU)
96h	READ_POUT	-	R	2	Linear	Returns the output power, in Watts.
97h	READ_PIN	-	R	2	Linear	Returns the input power, in Watts
99h	MFR_ID	-	R/W	8	ASCII	Artesyn
9Ah	MFR_MODEL	-	R/W	8	ASCII	LCM1500
9Bh	MFR_REVISION	-	R/W	2	ASCII	
9Ch	MFR_LOCATION	-	R/W	8	ASCII	Laguna
9Dh	MFR_DATE	-	R/W	8	ASCII	Manufacture Date, ASCII format structure : YYMMDD
9Eh	MFR_SERIAL	-	R/W	13	ASCII	13 CHAR

PMBUS™ SPECIFICATIONS

The LCM1500W Series Supported PMBus™ Command List:

Command Code	Command Name	Default Value	Access Type	Data Bytes	Data Format	Description
A0h	MFR_VIN_MIN	EAD0	R	2	Linear	Minimum Input Voltage (90Vac)
A1h	MFR_VIN_MAX	FA10	R	2	Linear	Maximum Input Voltage (264Vac)
A2h	MFR_IIN_MAX	DA40	R	2	Linear	Maximum Input Current (18A)
A4h	MFR_VOUT_MIN	1B00	R	2	Linear	Minimum Output Voltage Regulation Window. (13.5V)
A5h	MFR_VOUT_MAX	8448	R	2	Linear	Maximum Output Voltage. Regulation Window (16.5V)
A6h	MFR_IOUT_MAX	EB20	R	2	Linear	Maximum Output Current (100A)
A7h	MFR_POOUT_MAX	-	R	2	Linear	Maximum Output Power (1560W)
A8h	MFR_TAMBIENT_MAX	EA30	R	2	Linear	Maximum Operating Ambient Temperature (Secondary Ambient) (70 degC)
A9h	MFR_TAMBIENT_MIN	-	R	2	Linear	Minimum Operating Ambient Temperature (Secondary Ambient) (-40 degC)
E0h	FW_PRI_VERSION	-	BR	8	ASCII	Varies
E1h	FW_SEC_VERSION	-	BR	8	ASCII	Varies

PMBUS™ SPECIFICATIONS

I2C Reading Accuracy

Below is the typical accuracy specification for LCM1500 Series (For Reference Only)

Reporting Function	Command Code	Command Name	Accuracy Range
			20% to 100% load
Input Voltage	88h	READ_VIN	±5%
Output Voltage	8Bh	READ_VOUT	±5%
Output Current	8Ch	READ_IOUT	±5%
Input Current	89h	READ_IIN	±5%
Input Power	97h	READ_PIN	±20%
Output Power	96h	READ_POUT	±20%

APPLICATION NOTES

Current Sharing

The LCM1500 main output V1 is equipped with current sharing capability. This will allow up to 10 power supplies to be connected in parallel for higher power application. Current share accuracy is typically 10% of full load. SWP Node voltage at full load is to be 5.5 to 6.5 V and 2.5 to 3.5 V at 50% of maximum current. The minimum load at parallel operation is 1% of the total output current that the units can deliver.

The table below shows the derated maximum power capacity when units are in parallel configuration. This is to consider the 10% load sharing tolerance.

Number of Units in Parallel (N)	Maximum Output power Rated + [(N-1) x 0.9] x Rated, Where: Rated - 1500W, N - Number of PSU in Parallel
Stand-alone	1500W
2	2850W
3	4200W
4	5550W
...	...
10	13650

APPLICATION NOTES

Output Ripple and Noise Measurement

The setup outlined in the diagram below has been used for output voltage ripple and noise measurements on the LCM1500 series. When measuring output ripple and noise, a scope jack in parallel with a 0.1uF ceramic chip capacitor, and a 10 uF tantalum capacitor should be used. Oscilloscope should be set to 20 MHz bandwidth for this measurement.

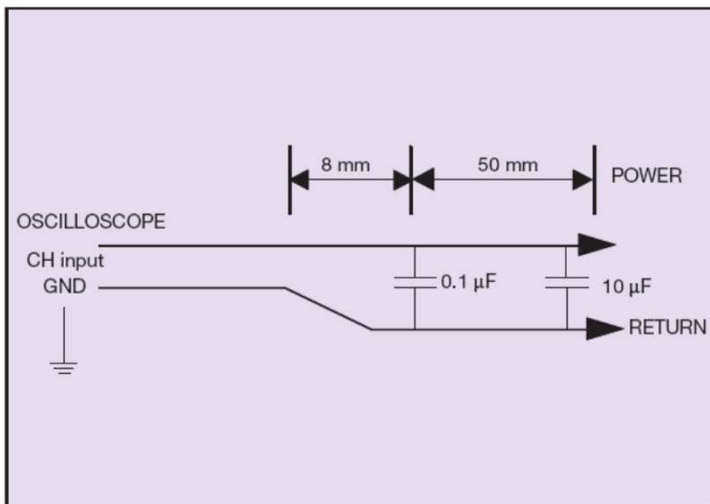

RECORD OF REVISION AND CHANGES

Issue	Date	Description	Originators
1.0	01.21.2014	First Issue	K. Wang
1.1	04.24.2014	Remove CCC cert	K. Wang
1.2	07.10.2014	Update type error	K. Wang
1.3	04.29.2014	Update the no load input current and power Add EMC section we missed before Update the model number(add the adjust range) Update hold up time from 20mS to 14mS	K. Wang
1.4	09.07.2015	Update type error	K. Wang
1.5	01.12.2016	Update the address issue	K. Wang
1.6	04.29.2016	1.Update input fuse to 30A 2. Update the description for remote sense	K. Wang
1.7	07.14.2016	Add the LCM1500L, LCM1500U, LCM1500R	K. Wang
1.8	04.20.2017	Update the load Capacitor	K. Wang
1.9	04.28.2017	Update the leakage current to 240Vac 0.3mA per safety confirm	K. Wang
2.0	05.09.2018	SCP mode update	K. Wang
2.1	05.16.2018	Remove minimum limit for T4	K. Wang
2.2	09.18.2018	1.Update the dynamic spec to 4% 2. Add the command list for other model	K. Wang
2.3	10.15.2018	"Delay from loss of AC input to 0 to G_ACOK_C going to high" Add "to 0"	K. Wang
2.4	02.19.2019	Update 21h to R/W	K. Wang
2.5	04.01.2019	Add the I2C Reading Accuracy	K. Wang
2.6	05.05.2019	Update mating connectors	K. Wang
2.7	10.29.2019	Update the regulation for V_{SB}	K. Wang
2.8	12.18.2019	Update timeout to 25mS	K. Wang
2.9	03.23.2020	Update Isolation Voltage	C.Liu
3.0	06.18.2020	1.Update the leakage current for different test method 2.Update the safety 60950 to 62368-1	K. Wang
3.1	07.22.2020	1.Update parallel number from 10 to 4 2.Add OCP mode	K. Wang
3.2	09.30.2020	Update PFC and DC DC switch frequency	K. Wang
3.3	10.20.2020	Update the 21h, 44h,46h	K. Wang
3.4	07.06.2021	Update typo for 1A/uS	K. Wang
3.5	08.10.2021	Update the isolation voltage and new picture with new logo	K. Wang
3.6	09.16.2021	Update adjust range lower limit for LCM1500W from 40.8V to 43.8V after testing and discus with DE	K. Wang
3.7	11.06.2021	Update transient response step load valid range	K. Zou
3.8	01.07.2022	1. UKCA 2. Remove D5h and add E0h,E1h	K. Wang
3.9	01.20.2022	1. Update mating connector 2. Add 3A,3B,3C 3. Timing	K. Wang

RECORD OF REVISION AND CHANGES

Issue	Date	Description	Originators
4.0	10.18.2022	Update EMC part typo	K. Wang
4.1	02.24.2023	Add Semi 47 compliance	K. Wang
4.2	09.04.2023	Add LCM1500L fan noise spec Update Number of Parallel Units to 10	K. Wang
4.3	12.06.2023	Update the SCL, SDA description Update typo LCM1500W 46h. It's read only	K. Wang



For international contact information,
visit advancedenergy.com.

powersales@aei.com (Sales Support)
productsupport.ep@aei.com (Technical Support)
+1 888 412 7832

ABOUT ADVANCED ENERGY

Advanced Energy (AE) has devoted more than three decades to perfecting power for its global customers. AE designs and manufactures highly engineered, precision power conversion, measurement and control solutions for mission-critical applications and processes.

Our products enable customer innovation in complex applications for a wide range of industries including semiconductor equipment, industrial, manufacturing, telecommunications, data center computing, and medical. With deep applications know-how and responsive service and support across the globe, we build collaborative partnerships to meet rapid technological developments, propel growth for our customers, and innovate the future of power.

PRECISION | POWER | PERFORMANCE | TRUST

Specifications are subject to change without notice. Not responsible for errors or omissions. ©2020 Advanced Energy Industries, Inc. All rights reserved. Advanced Energy®, and AE® are U.S. trademarks of Advanced Energy Industries, Inc.

LCM1500 Rev 12.13.23_#4.3