

# ARTESYN PTH12030

12 Vin Single Output



Advanced Energy's Artesyn PTH12030 series of non-isolated DC-DC converters complies with the Point-of-Load Alliance (POLA) standard. The converters offer some of the most advanced POL functions in the industry, including Auto-Track™ sequencing for controlled power-up/power-down of complex semiconductor devices such as DSPs, FPGAs and ASICs, and voltage margining. Standard features include pre-bias startup, input undervoltage lockout, remote sense, remote On/Off and auto resetting short-circuit protection.

There are two models in the PTH12030 series of converters, both of which have an input voltage range of 10.8 to 13.2 Vdc. One model offers an output voltage that can be trimmed from 0.8 to 1.8 Vdc, the other has an output that can be trimmed from 1.2 to 5.5 Vdc, enabling a broad diversity of semiconductor power needs to be satisfied. The 0.8 to 1.8 V output converter offers up to 89% efficiency while the higher output voltage model can achieve up to 94.5%. Both converters are rated at 143 watts output power and can deliver up to 26 amps. Available in through-hole horizontal mount and surface-mount versions, they have a small 1.1 x 1.37 inch (28.4 x 34.8 mm) footprint and an installed height of just 0.35 inch (9 mm).

## SPECIAL FEATURES

- 26 A output current
- 12 V input voltage
- Wide-output voltage adjust:  
1.2 - 5.5 Vdc for suffix 'W'  
0.8 - 1.8 Vdc for suffix 'L'
- Auto-track™ sequencing\*
- Margin up/down controls
- Efficiencies up to 94.5%
- Output ON/OFF inhibit
- Output voltage sense
- Point-of-Load-Alliance (POLA) compatible
- RoHS compliant
- Two year warranty

## DATA SHEET

### Total Power:

143 Watts

### # of Outputs:

Single



\*Auto-track is a trademark of Texas Instruments.

## SAFETY

- UL/cUL CAN/CSA-C22.2 No. 60950-1-03/UL 60950-1, File No. E174104
- TÜV Product Service (EN60950) Certificate No B 04 06 38572 044
- CB Report and Certificate to IEC60950, Certificate No. US/8292/UL

**ELECTRICAL SPECIFICATIONS**

Input		
Input voltage range	(See Note 3)	10.2 - 13.2 Vdc
Input current	No load	10 mA typical
Remote ON/OFF	(See Note 1)	Positive logic
Start-up time		1 V/ms
Undervoltage lockout		8.5 - 9.5 V typical
Track input voltage	Pin 11 (See Notes 6 )	±0.3 Vin
Output		
Voltage adjustability	(See Note 4)	1.2 - 5.5 Vdc (Suffix 'W') 0.8 - 1.8 Vdc (Suffix 'L')
Setpoint accuracy		±2.0% Vo
Line regulation		±5 mV typical
Load regulation		±5 mV typical
Total regulation		±3.0% Vo
Minimum load		0 A
Ripple and noise	20 MHz bandwidth (See Note 8)	25 mV pk-pk (Suffix 'W') 15 mV pk-pk (Suffix 'L')
Temperature co-efficient	-40 °C to +85 °C	±0.5% Vo
Transient response	(See Note 5)	50 µs recovery time Overshoot/undershoot 150 mV
Margin adjustment		±5.0% Vo

All specifications are typical at nominal input, full load at 25 °C unless otherwise stated.  
Cin = 560 µF, Cout = 0 µF.

**GENERAL SPECIFICATIONS**

Efficiency		See Efficiency Table
Insulation voltage		Non-isolated
Switching frequency	Over Vin and Io ranges	575 kHz typ
Approvals and standards		EN60950, UL/cUL60950
Material flammability		UL94V-0
Dimensions	L x W x H	34.80 x 28.45 x 9.00 mm 1.370 x 1.120 x 0.354 in
Weight		7 g (0.25 oz)
MTBF	Telcordia SR-332	2,821,000 hours

## EMC CHARACTERISTICS

Electrostatic discharge	EN61000-4-2, IEC801-2
Conducted immunity	EN61000-4-6
Radiated immunity	EN61000-4-3

## ENVIRONMENTAL SPECIFICATIONS

Thermal performance (See Note 2)	Operating ambient temperature Non-operating temperature	-40 °C to +85 °C -40 °C to +125 °C
MSL ('Z' suffix only)	JEDEC J-STD-020C	Level 3
Protection		
Short-circuit	Auto reset	40 A typical
Thermal		Auto recovery

## ORDERING INFORMATION

Model Number <sup>(®)</sup>	Output Power (Max.)	Input Voltage	Output Voltage	Output Current (Min.)	Output Current (Max.)	Efficiency (Typical)	Regulation	
							Line	Load
PTH12030L	143 W	10.8 - 13.2 Vdc	0.8 - 1.8 Vdc	0 A	26 A	89%	±5 mV	±5 mV
PTH12030W	143 W	10.8 - 13.2 Vdc	1.2 - 5.5 Vdc	0 A	26 A	94.5%	±5 mV	±5 mV

## PART NUMBER SYSTEM WITH OPTIONS

Product Family	Input Voltage	Output Current	Mechanical Package	Output Voltage Code	Pin Option <sup>(®)</sup>	Mounting Options	Pin Option
<b>PTH</b>	<b>12</b>	<b>03</b>	<b>0</b>	<b>W</b>	<b>A</b>	<b>S</b>	<b>T</b>
Point-of-Load Alliance compatible	12 = 12 V	03 = 26 A	Always 0	W = Wide L = Low Voltage		D = Horizontal through-hole (RoHS 6/6) Z = Surface-mount solder ball (RoHS 6/6)	No Suffix = Trays T = Tape and Reel <sup>(®)</sup>

**OUTPUT VOLTAGE ADJUSTMENT**

The ultra-wide output voltage trim range offers major advantages to users who select the PTH12030. It is no longer necessary to purchase a variety of modules in order to cover different output voltages. The output voltage can be trimmed in a range of 1.2 Vdc to 5.5 Vdc for suffix 'W' and 0.8 Vdc to 1.8 Vdc for suffix 'L'. When the PTH12030 converter leaves the factory the output has been adjusted to the default voltage of 1.2 V for the PTH12030W and 0.8 V for the PTH12030L.

Efficiency Table: PTH12030W (Io = 18 A)	
Output Voltage	Efficiency
Vo = 5.0 V	94.5%
Vo = 3.3 V	92.7%
Vo = 2.5 V	91.4%
Vo = 2.0 V	90.3%
Vo = 1.8 V	89.5%
Vo = 1.5 V	88.2%
Vo = 1.2 V	86.2%
Efficiency Table: PTH12030L (Io = 18 A)	
Output Voltage	Efficiency
Vo = 1.8 V	89%
Vo = 1.5 V	87%
Vo = 1.2 V	85%
Vo = 1.0 V	83%
Vo = 0.8 V	80%

Notes:

- Remote ON/OFF, Positive Logic  
 ON: Pin 4 open; or V > Vin - 0.5 V  
 OFF: Pin 4 GND; or V < 0.8 V (min - 0.2 V).
- See Figure 1 for safe operating curve of the PTH12030W and Figure 4 for safe operating curve of the PTH12030L.
- A 560 µF electrolytic input capacitor is required for proper operation. The capacitor must be rated for a minimum of 800 mA rms of ripple current.
- An external output capacitor is not required for basic operation. Adding 330 µF of distributed capacitance at the load will improve the transient response.
- 1 A/µs load step, 50 to 100% Iomax, Cout = 330 µF.
- If utilized Vout will track applied voltage by ±0.3 V (up to Vo set point).
- Tape and reel packaging only available on the surface-mount versions.
- NOTICE: Some models do not support all options. Please contact your local Artesyn representative or use the on-line model number search tool at <http://www.artesyn.com> to find a suitable alternative.

PTH12030W CHARACTERISTIC DATA

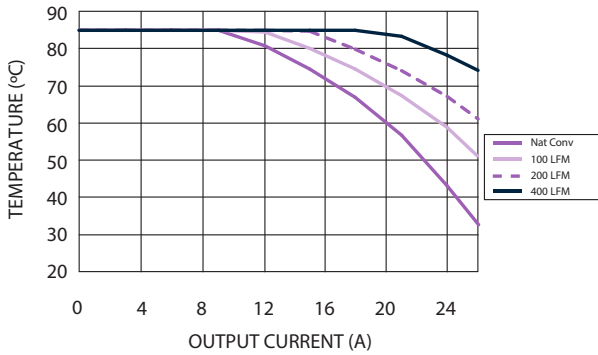

Figure 1 - Safe Operating Area  
 Vin = 12 V, Output Voltage = 3.3 V (See Note A)

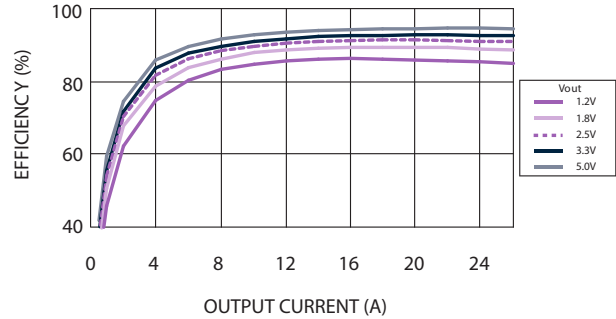

Figure 2 - Efficiency vs Load Current  
 Vin = 12 V (See Note B)

PTH12030L CHARACTERISTIC DATA

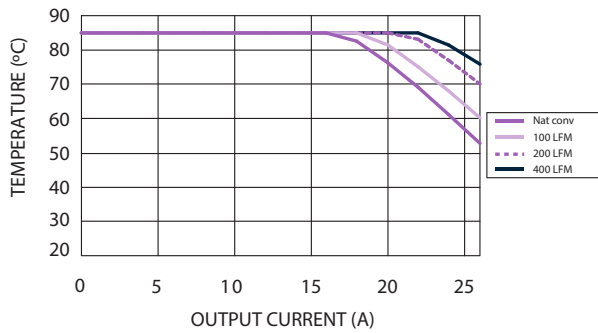

Figure 3 - Safe Operating Area  
 Vin = 12 V, Output Voltage ≤ 1.8 V (See Note A)

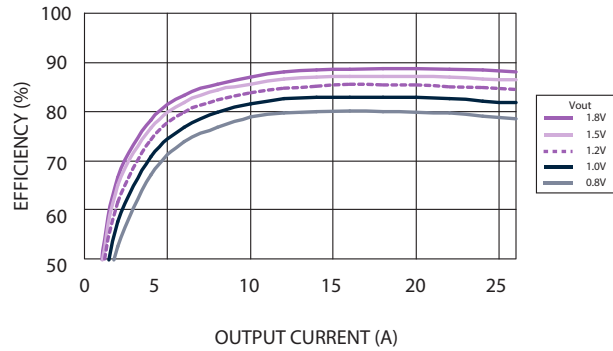

Figure 4 - Efficiency vs Load Current  
 Vin = 12 V (See Note B)

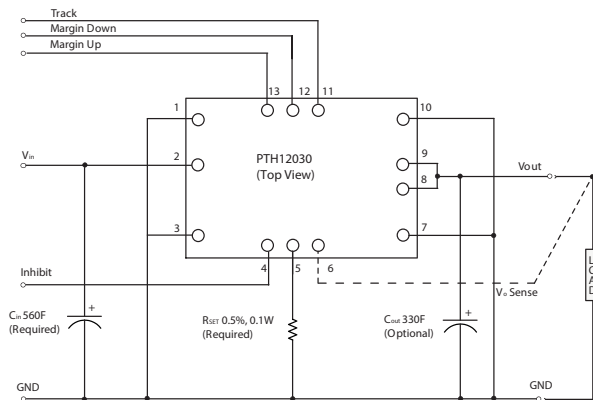

Figure 5 - Standard Application - All Models

Notes:

- A. SOA curves represent the conditions at which internal components are within the Artesyn derating guidelines.
- B. Characteristic data has been developed from actual products tested at 25 °C. This data is considered typical data for the converter.

MECHANICAL DRAWINGS

Plated through-hole

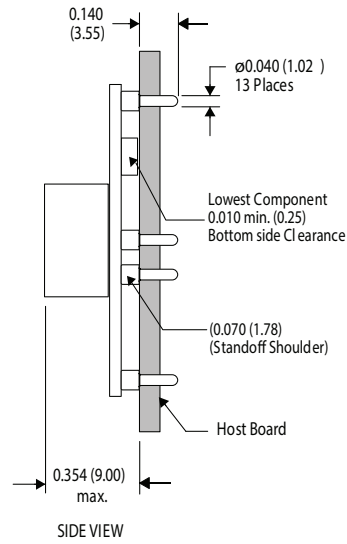
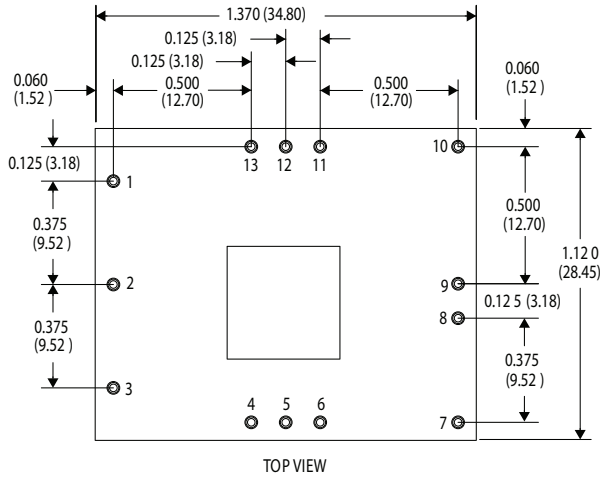

Dimensions in Inches (mm)  
Tolerances (unless otherwise specified)  
2 Places 0.030 (0.76)  
3 Places 0.010 (0.25)

Surface-mount

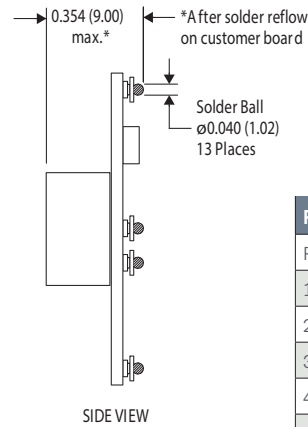
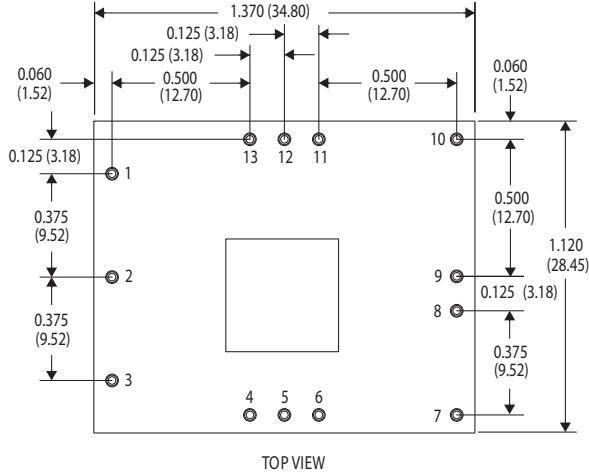

Dimensions in Inches (mm)  
Tolerances (unless otherwise specified)  
2 Places 0.030 (0.76)  
3 Places 0.010 (0.25)

Pin Assignments	
Pin	Function
1	Ground
2	Vin
3	Ground
4	Inhibit*
5	Vo adjust
6	Vo sense
7	Ground
8	Vout
9	Vout
10	Ground
11	Track
12	Margin down*
13	Margin up*

\*Denotes negative logic:  
Open = Normal operation  
Ground = Function active



For international contact information,  
visit [advancedenergy.com](http://advancedenergy.com).

[powersales@aei.com](mailto:powersales@aei.com) (Sales Support)  
[productsupport.ep@aei.com](mailto:productsupport.ep@aei.com) (Technical Support)  
+1 888 412 7832

## ABOUT ADVANCED ENERGY

Advanced Energy (AE) has devoted more than three decades to perfecting power for its global customers. AE designs and manufactures highly engineered, precision power conversion, measurement and control solutions for mission-critical applications and processes.

Our products enable customer innovation in complex applications for a wide range of industries including semiconductor equipment, industrial, manufacturing, telecommunications, data center computing, and medical. With deep applications know-how and responsive service and support across the globe, we build collaborative partnerships to meet rapid technological developments, propel growth for our customers, and innovate the future of power.

PRECISION | POWER | PERFORMANCE

---

Specifications are subject to change without notice. Not responsible for errors or omissions. ©2021 Advanced Energy Industries, Inc. All rights reserved. Advanced Energy®, AE® and Artesyn™ are U.S. trademarks of Advanced Energy Industries, Inc.